

POMPE A PISTONI AD ASSE INCLINATO BENT AXIS PISTON PUMPS

CODICE FAMIGLIA
FAMILY CODE

601-001

"HDS"

Flangia/Flange
Albero/Shaft
Cilin./Displ.

ISO
ISO14 8x32x36
12-17-25-34



Fluido idraulico Fluid	Minerale o sintetico compatibile con guarnizioni: Mineral or synthetic compatible with the following seals: FKM, FPM, HNBR				
Viscosità cinematica consigliata Kinematic viscosity suggested	T media ambiente (°C) Average ambient temp. (°C)	< -40	-40 ÷ 10	10 ÷ 35	> 35
	VG (cSt = mm ² /s)	16	22	32	46
Viscosità cinematica ottimale di esercizio Optimale kinematic viscosity		VG = 10 cSt ÷ 100 cSt			
Viscosità cinematica max consentita all'avviamento Max kinematic viscosity suggested at the start-up		VG = 750 cSt			
Indice di viscosità consigliato Viscosity index suggested	VI > 100	Temperatura di esercizio Working temperature -40°C ÷ 140°C			
Grado di filtrazione Oil filtering		> 200 bar: 10 µm < 200 bar: 25 µm			
Pres. di aspirazione Inlet pressure		0,85 ÷ 2 bar assoluti/absolut			
Senso di rotazione Pump rotation		Unidirezionale (Dx o Sx) Unidirectional (Right or Left)			
Verificare che la pompa sia posizionata almeno 100 mm sotto il livello minimo del serbatoio olio. Prima di avviare la pompa effettuare spurgo aria. Verify that pump is, at least, 100 mm under the minimum level of the tank. Before starting the pump bleed the air.					

Codice fascicolo: 997-400-60010 Rev: AL

Data: Mercoledì 30 marzo 2016

Rev: //

Codice foglio: 997-601-01510

Dimensions in mm

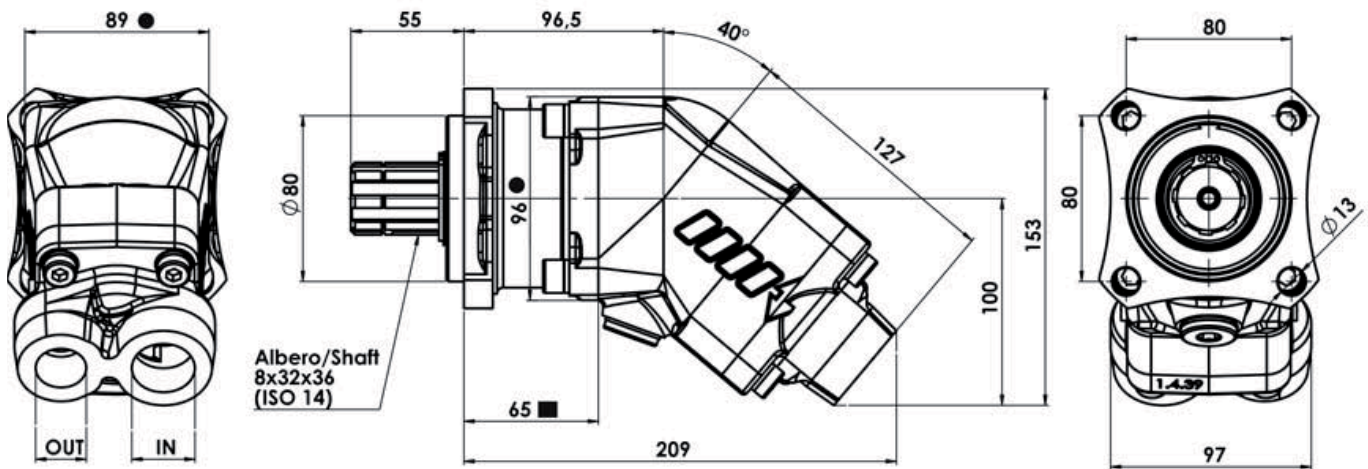

● Larghezza minima corpo a quota indicata ■
Minimum bodywidth at indicated measurement

Tipo pompa Pump type	Rotazione Rotation		IN	OUT	IN	OUT
	Destra Right	Sinistra Left				
HDS-12	601-001-10123	601-001-10129	ISO 228 G 1	ISO 228 G 3/4	SAE	SAE
HDS-17	601-001-10173	601-001-10179	G 1	G 3/4		
HDS-25	601-001-10253	601-001-10259	G 1	G 3/4		
HDS-34	601-001-10343	601-001-10349	G 1	G 3/4		

pag.27

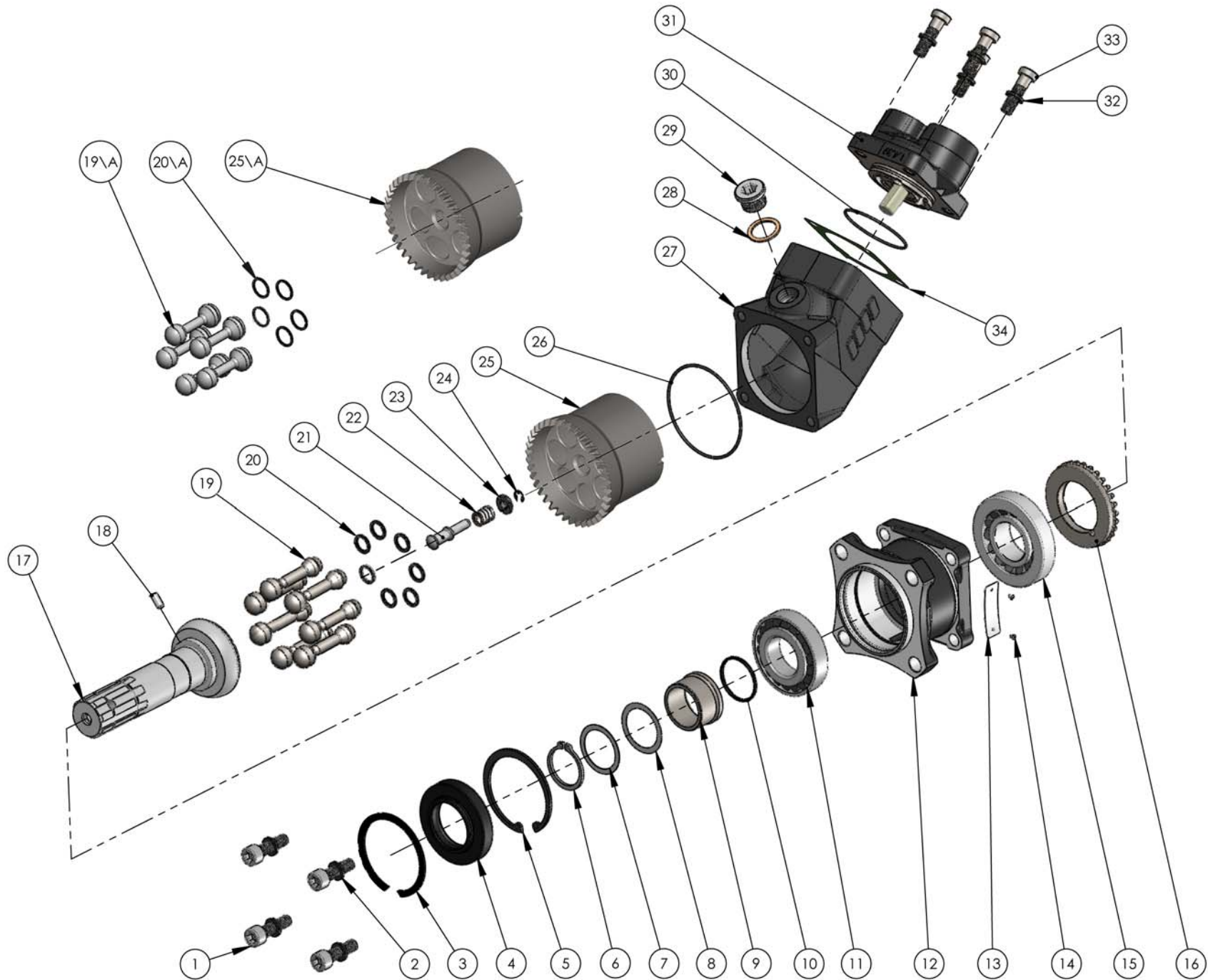

pag. 28

COMPANY WITH
QUALITY SYSTEM
CERTIFIED BY DNV GL
= IATF 16949 =

O.M.F.B. S.p.A. Hydraulic Components
We reserve the right to make any changes without notice.
Edition 2016.06 No reproduction, however partial, is permitted.
Via Cove, 7/9 25050 Provedolo d'Isco (Brescia) Italy Tel.: +39 030 9830611
Fax: +39 030 9839207-208 Internet: www.omfb.it e-mail: info@omfb.it

OMFB
HYDRAULIC COMPONENTS



O.M.F.B. S.p.A. Hydraulic Components
 We reserve the right to make any changes without notice.
 Edition 2016.06 No reproduction, however partial, is permitted.
 Via Cove, 719 25050 Povoaglio d'Isèo (Brescia) Italy Tel.: +39 030 9830611
 Fax: +39 030 9839207-208 Internet:www.omfb.it e-mail:info@omfb.it

pag. 29

COMPANY WITH
 QUALITY SYSTEM
 CERTIFIED BY DNV GL
 = IATF 16949 =

N° N°	HDS 12 GAS	HDS 17 GAS	HDS 25 GAS	HDS 34 GAS	Codice P. Number	Description Description	Q.tà Q.ty	
1	•	•	•	•	502-004-00565	Vite TCE M 10x35	Socket head capscrew	4
2	•	•	•	•	501-008-00054	Rosetta elastica	Washer	4
3	•	•	•	•	501-000-02729	Anello elastico	Circlip	1
4	•	•	•	•	506-000-24272	Paraolio	Oil seal	1
5	•	•	•	•	501-001-00677	Anello elastico	Circlip	1
6	•	•	•	•	501-000-01355	Anello seeger rinforzato	Retaining ring	1
7	•	•	•	•	529-007-01127	Rondella	Spacers	2
8	•	•	•	•	529-007-00226	Rondella	Spacers	2
9	•	•	•	•	511-002-00200	Bussola	Bushing	1
10	•	•	•	•	506-000-13137	Guarnizione OR	O-ring	1
11	•	•	•	•	510-002-00211	Cuscinetto a rulli conici	Tapered roller bearing	1
12	•	•	•	•	517-002-01154	Corpo anteriore	Front housing	1
13	•	•	•	•	513	Targhetta completa	Plate	1
14	•	•	•	•	513-000-00011	Chiodino fiss. targhetta	Plate nail	2
15	•	•	•	•	510-002-00373	Cuscinetto a rulli conici	Tapered roller bearing	1
16	•	•	•	•	525-011-00264	Corona dentata	Crown	1
17	•	•	•	•	522-005-00357	Albero	Shaft	1
18	•	•	•	•	522-005-00268			
19	•	•	•	•	501-003-06142	Spina UNI 6364	Pin UNI 6364	1
19A	•	•	•	•	532-005-00061	Pistone sferico	Piston	7
20	•	•	•	•	532-005-00052			
20A	•	•	•	•	532-005-00061			5
21	•	•	•	•	532-005-00052			
22	•	•	•	•	501-023-00064	Fasce elastiche	Spring rings	21
23	•	•	•	•	501-023-00073			
24	•	•	•	•	501-023-00064			15
25	•	•	•	•	501-023-00073			
26	•	•	•	•	542-001-00313	Perno sferico con guida albero	Shaft guide pin	1
27	•	•	•	•	542-001-00162			
28	•	•	•	•	512-005-01651	Molla di carico corpo cilindri	Spring	1
29	•	•	•	•	512-005-00812			
30	•	•	•	•	542-001-00322	Anello guida molla	Spring guide ring	1
31	•	•	•	•	542-001-00171			
32	•	•	•	•	501-015-00046	Anello seeger	Retaining ring	1
33	•	•	•	•	501-015-00028			
34	•	•	•	•	500-029-16034	Gruppo corpo cilindri sede pistoni	Piston barrel assembly	1
35	•	•	•	•	500-029-16025			
36	•	•	•	•	500-029-16017			
37	•	•	•	•	500-029-16012			
38	•	•	•	•	506-000-18020	Guarnizione OR	O-ring	1
39	•	•	•	•	517-002-00717	Corpo intermedio	Int. housing	1
40	•	•	•	•	116-009-10129	Rondella rame	Copper washer	1
41	•	•	•	•	115-006-00135	Tappo cieco	Blank plug	1
42	•	•	•	•	506-000-12224	Guarnizione OR	O-ring	1
43	•	•	•	•	500-029-80340	Gruppo corpo posteriore	Rear cover assembly	1
44	•	•	•	•	500-029-80251			
45	•	•	•	•	500-029-80171			
46	•	•	•	•	500-029-80126			
47	•	•	•	•	501-020-00101	Rosetta elastica	Washer	4
48	•	•	•	•	502-004-00556	Vite TCE M10x30	Socket head capscrew	4
49	A	A	A	A	507-000-00256	Guarnizione piatta	Gasket	1
50	A	A	A	A	507-000-00523			

A = alternative

CARATTERISTICHE TECNICHE DI FUNZIONAMENTO / TECHNICAL FEATURES

Tipo pompa Pump type	Cilindrata Displacement cm ³ /rev	Pressione Pressure		Velocità / Speed			Velocità min. Min. speed rpm	Peso Weight kg
		P1 bar	P3 bar	V0 rpm	V1 rpm	V2 rpm		
HDS-12	12.62	350	400	3000	2300	3000	300	8,7
HDS-17	16.98							
HDS-25	25.12							
HDS-34	33.80							

P1=Pressione massima continua Max. continuous pressure (100%)
P3=Pressione massima di punta Max. peak pressure (6 sec.max)

V0=Massima continua vuoto Max. continuous speed without load
V1=Massima continua Max. continuous speed
V2=Massima intermittente Max. intermittent speed

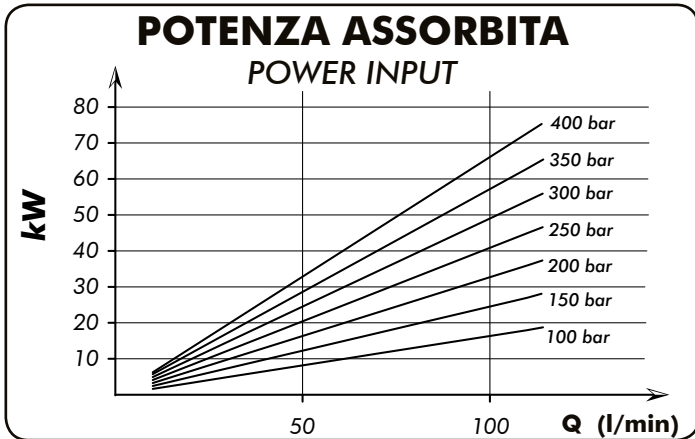
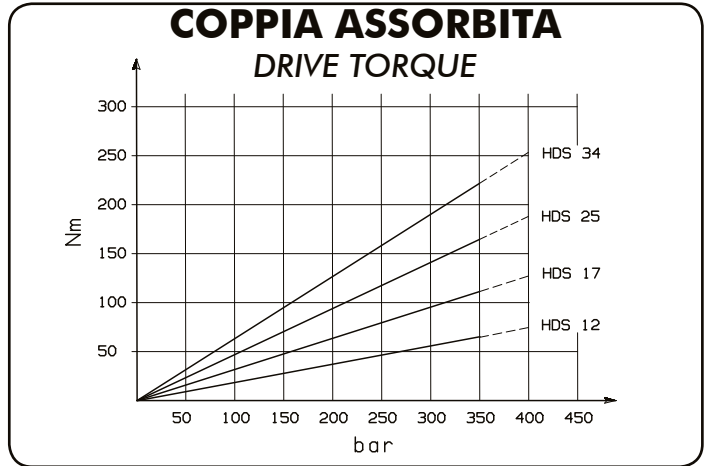
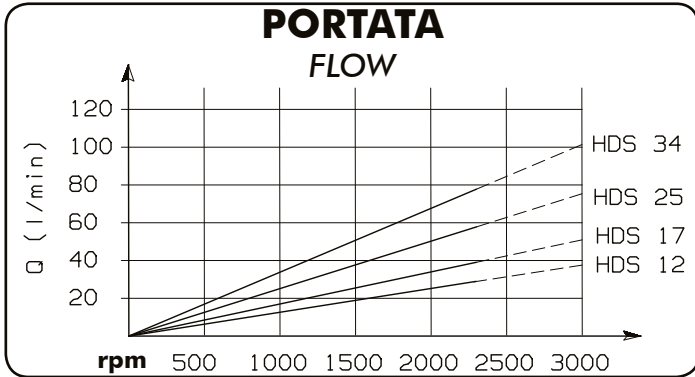

SCelta DEL TUBO DI ASPIRAZIONE / HOW TO CHOOSE THE SUCTION PIPE SIZE

Q Portata Flow l/min	Ø interno min. tubo Min pipe diam. mm	inch	Velocità flusso Flow speed (m/s)
20	25	1"	0,68
30	32	1" 1/4	0,62
40	32		0,83
50	38	1" 1/2	0,74
60	38		0,88
70	40	1" 9/16	0,93
80	45	1" 3/4	0,84
90	45		0,94
100	50	2"	0,85
110	50		0,93
120	60	2" 3/8	0,71
130	60		0,77
140	60		0,83
150	60		0,88
160	63	2" 1/2	0,86
170	63		0,91
180	63		0,96

Per garantire corrette condizioni di aspirazione la velocità del flusso non deve superare 1 m/sec.
To ensure the proper suction pipe size the flow speed should not exceed 1mt/sec.

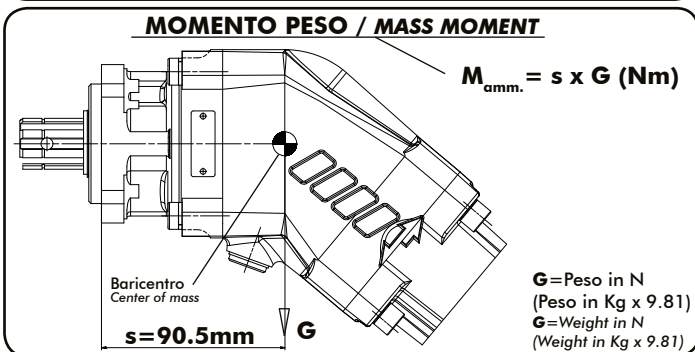

Kit guarnizioni / Seal Kit
108-903-25340