

## ISO 14 (DIN 5462)

CODICE DI ORDINAZIONE / ORDERING CODE

### 201 PE XXX Z SE

TIPO / TYPE: POMPA A PISTONI / PISTON PUMP  
 CILINDRATA / DISPLACEMENT: XXX  
 VERSIONE / VERSION: Z  
 ISO 14 (DIN 5462)

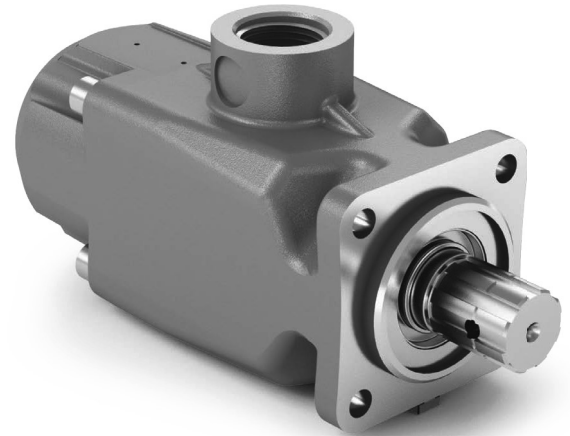

2

**BIDIREZIONALE**  
**BI-ROTATIONAL**

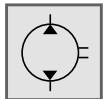

**PE 40**

**PE 50**

**PE 60**

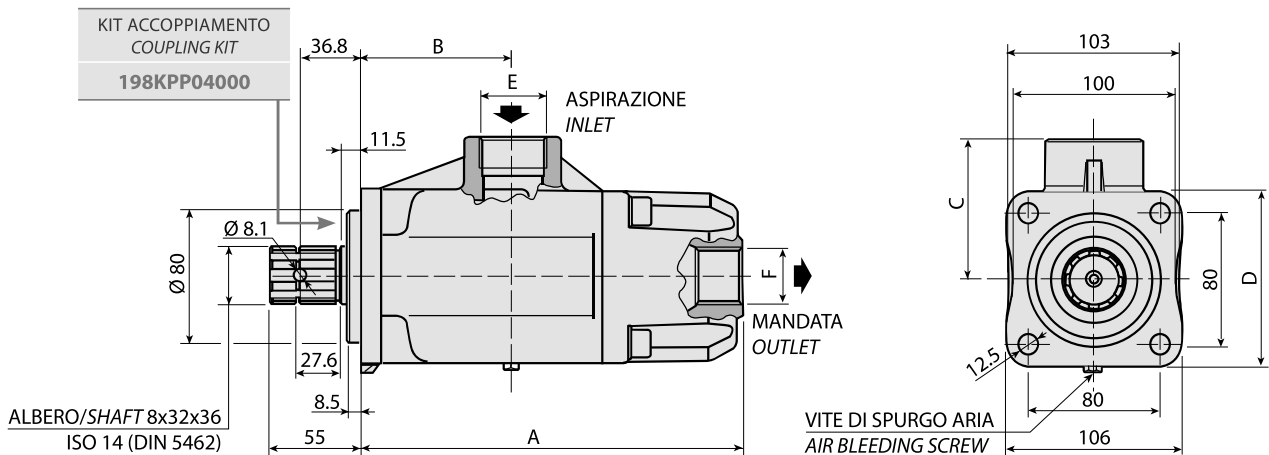

### CARATTERISTICHE E DATI TECNICI / SPECIFICATIONS AND TECHNICAL DATA

TIPO TYPE	CODICE CODE	A mm	B mm	C mm	D mm	E ASPIRAZIONE INLET	F MANDATA OUTLET	PESO WEIGHT kg
<b>PE 40</b>	<b>201PE040ZSE</b>	232.5	945	85	106	1" 1/4 G	1" G	10.6
<b>PE 50</b>	<b>201PE050ZSE</b>							
<b>PE 60</b>	<b>201PE060ZSE</b>							

Per la scelta dei raccordi orientabili vedi pag. 214-215 / For the selection of adjustable fittings see page 214-215

- A richiesta possono essere fornite le pompe a pistoni con le guarnizioni HNBR per climi freddi (-40 °C).
- On request our piston pumps may be supplied with HNBR seals for cold climates (-40 °C).

**ISO 14 (DIN 5462)**

TIPO / TYPE		PE 40	PE 50	PE 60
Cilindrata <i>Displacement</i>	Vg cm <sup>3</sup> /n cm <sup>3</sup> /rev.	37	50	60
Pressione massima continua <i>Max continuous operating pressure</i>	P1	330	330	290
Pressione massima intermittente <i>Max intermittent operating pressure</i>	(max 30 s) P2	360	360	340
Pressione massima di picco <i>Max peak pressure</i>	(≤ 0.1 s) P3	500	500	400
Velocità massima intermittente <i>Max intermittent speed</i>	(P ≤ 20 bar) n3	2400	2400	2100
Velocità massima continua <i>Max continuous speed</i>	(≤ P1) n1	1800	1800	1700
Velocità minima intermittente <i>Min intermittent speed</i>	(≤ P2 x 0.5) (max 30 s) n4	400	400	300

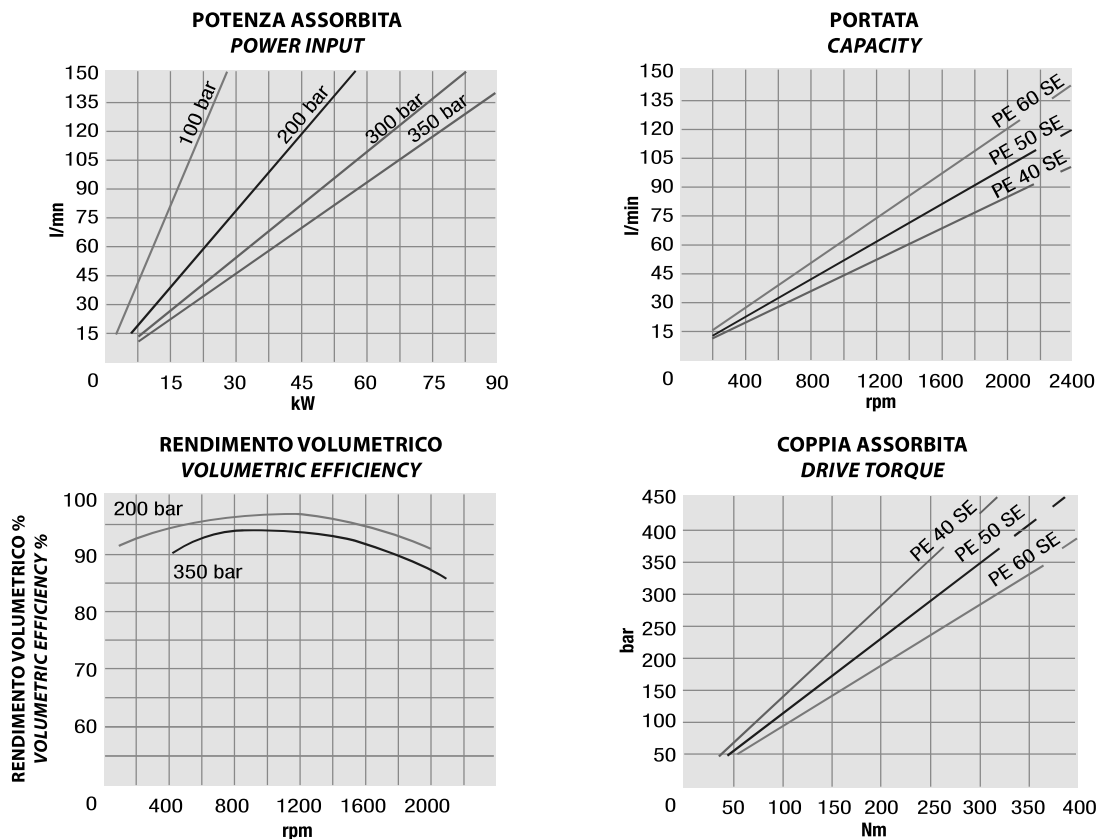
**2**
**DIAGRAMMI / DIAGRAMS**

RILIEVI ESEGUITI CON OLIO ISO VG 46 A 50° C ( $\nu = 30$  cSt)  
 THE ABOVE SPECIFICATIONS REFER TO OIL TYPE ISO VG 46 AT 50° C ( $\nu = 30$  cSt)