

ENGINEERING
TOMORROW



Technical Information
SystemStak™ Valves
DGMxx-5 30 Design



General Description

Danfoss SystemStak™ valves make compact hydraulic systems in which modular valves are “sandwich” mounted between a directional valve and a standard mounting surface. Compact design improves system response by elimination of external fluid conductors, thereby resulting in elimination of resonant sounds which are noisy and lead to leakage. The design of these valves is well proven and offers opportunities for achieving small control assemblies, especially when the valves are used with multi-station manifolds.

Mounting surface is available for interfacing with directional valves and is coded “5” in the model numbers of Danfoss SystemStak valves. The “5” interface accepts Danfoss DG4S4 directional valves and other directional valves with a standard ISO 4401-05, NFPA-D05, ANSI/B93.7M size D05 or CETOP-5 port pattern.

Each valve “stak” can be configured to provide the specific combination of functions required to meet the system’s needs.

SystemStak valves are divided into two groups:

1. Valves acting in the pressure and/or tank lines (“P” and/or “T”)

| | |
|--------------|-------------------|
| DGMC | Relief valve |
| DGMDC | Direct check |
| DGMFN | Flow control |
| DGMR1 | Sequence valve |
| DGMX2 | Pressure reducing |

The general rule for this group is that the DGMC relief valve be placed nearest the subplate or manifold. The DGMDC direct check valve should be placed nearest the directional control valve.

The DGMR1 sequence valve should be the farthest valve from the directional valve. The DGMR1 must be mounted directly to a subplate or manifold with a drain port, to externally drain the DGMR1 at the mounting face.

2. Valves acting in the service lines (“A” and/or “B”)

| | |
|--------------|----------------------|
| DGMC | Relief valve |
| DGMC2 | Dual relief valve |
| DGMDC | Direct check |
| DGMPC | Pilot operated check |
| DGMFN | Flow control |
| DGMR | Counterbalance |

The general rule for this group is that the DGMC system relief valve be the farthest valve from the directional valve.

When using a DGMPC with a DGMFN (meter-out), the DGMPC should be nearest the directional valve.

Features and Benefits

- **Reduced space requirements**

Stackable SystemStak valves, used with ISO 4401-05, CETOP 5 (NFPA-D05) directional controls, provide compact cost-effective control of actuator direction, speed and force.

- **Reduced installed cost**

SystemStak valves eliminate all intervalve piping and connections, thereby reducing the number of potential leakage points. Installed cost is less than when using conventional subplate- or line-mounted valves.

- **Versatile & easy to install**

SystemStak valves have all the internal passages necessary to serve the directional valve mounted above them. Any directional valve with a standard ISO 4401-05, NFPA-D05, ANSI/B93.7M size D05 or CETOP-5 port pattern can be used with ISO 4401-05 SystemStak valves.

Danfoss bolt-extender kits simplify valve installation by permitting each valve body to be separately and quickly installed, and correctly torqued down. The kits also allow the directional valve to be removed for service or replacement without disturbing the stack.

- **Rugged & reliable**

Internal working parts are produced from hardened steel, and reside in a continuous-cast ductile (spheroidal graphite) iron body. Excellent reliability is ensured, even in high pressure applications. Working parts are serviceable without removing valves from the stack.

Easy to Understand, Easy to Design

SystemStak circuitry is best shown using slightly different symbols than those for traditional valve configurations. Each SystemStak symbol has the same basic form and size as shown in Figure 1.

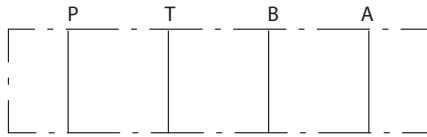

Figure 1.

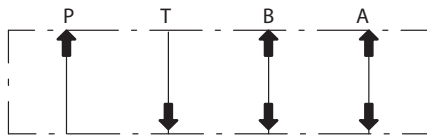

Figure 2.

For ease of understanding, remember the directions of flow for each line, and that all four flow paths pass through each valve (see Figure 2). For clarity, directional valves are drawn vertically in SystemStak circuit diagrams (see Figure 3.)

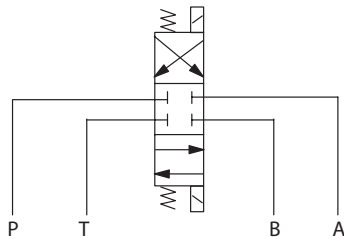

Figure 3.

Each station (valve stack) is a combination of functions. When designing and assembling SystemStak valves, care must be taken to ensure that they interact as required by stacking the functions in the correct sequence (see Figure 4). Direct check valves should be placed closest to the directional valve. Relief valves should normally be positioned next to the mounting surface (i.e. at the bottom of the stack). When both a flow control and a pilot operated check valve is required, it is recommended that the flow control valve be between the check valve and the actuator to prevent check valve chatter.

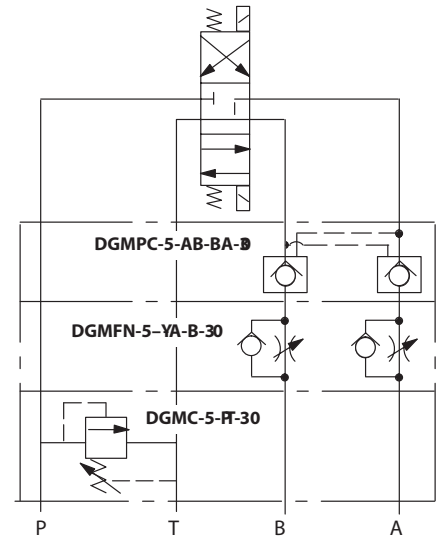

Figure 4.

A combination of directional valve, SystemStak valve(s) and subplate/ manifold block (Figure 5 single station subplate and Figure 6 multi station manifold) completes the assembly.

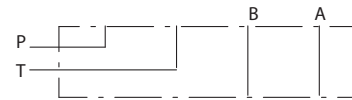

Figure 5.

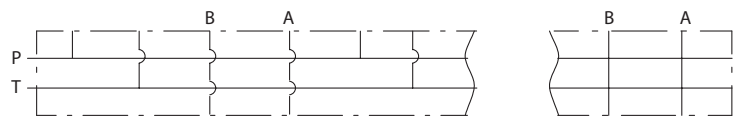

Figure 6.

Figure 7 represents a complete SystemStak system, showing typical use of functions available from this range. The circuit diagram also shows the use of a tapping plate for accessing line pressure readings, and a blanking plate to close off an unused station of a multi-station manifold.

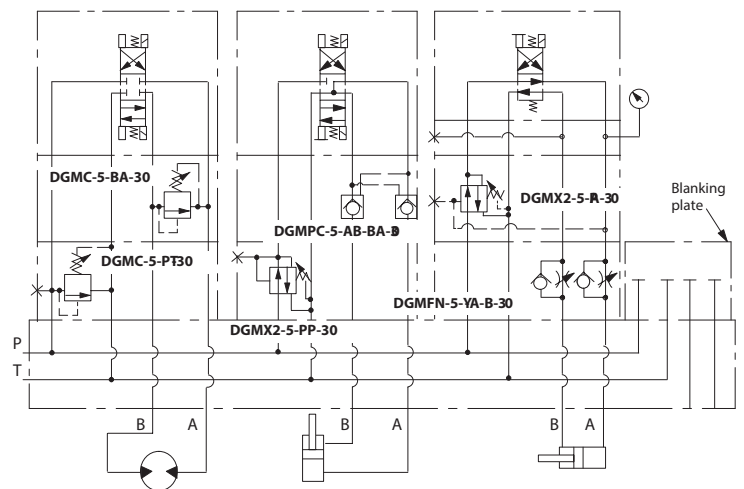

Figure 7.

Table of Contents



| Function | Basic symbol | Basic model | Features | Page |
|----------------------|--------------|-------------|--|------|
| Relief | | DGMC/DCMC2 | Single, dual and crossport models | 5 |
| Reducing/relieving | | DGMX2 | Piloted from (and reduced pressure in) port P, A or B | 13 |
| Sequence | | DGMR1 | Single port P sequence | 17 |
| Counterbalance | | DGMR | Control in port T | 20 |
| Flow Control | | DGMFN | Single or dual port, meter-in or meter-out | 24 |
| Pilot operated check | | DGMPC | Single in port A or B; dual in ports A and B | 29 |
| Direct check | | DGMDC | Single check in any port; dual check in ports A and B only | 32 |

SystemStak™ Pilot Operated Relief Valves



DGMC/DGMC2

General Description

These two-stage valves limit system pressure by directing flow to tank or the opposite cylinder port (A-B/B-A crossport types) when system pressure reaches the valve setting.

Pressure control may be obtained in "A", "B", "A" and "B", or "P" port, and pilot flow may be internally or externally drained, depending on model type. Any pressure in the line to which these valves are drained is additive to the valve pressure setting.

The valve pressure setting is adjustable by means of either an adjusting screw and locknut, a hand-knob adjuster, or a micrometer knob with keylock. External remote control/vent connections are available on all models except crossport relief. If required on crossport models, contact your Danfoss representative.

Model Code

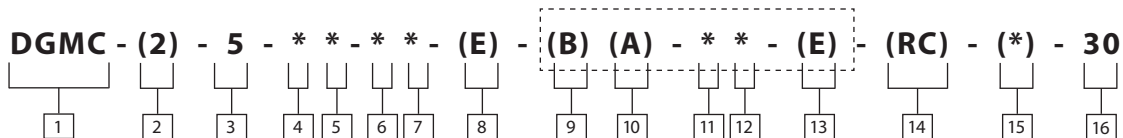

1 Valve function

Manifold or subplate mounted pressure relief valve.

2 Valve type

2 – Dual relief cavities

Blank – Single relief

3 Interface

5 – ISO 4401-AC-05-4-A, CETOP RP35H
ANSI/NFPA D05

4 Port operated upon

A – "A" cylinder port (single, dual or crossport types)

B – "B" cylinder port (single type only)

P – Pressure port (single type only)

5 Port drained into

A – "A" cylinder port

B – "B" cylinder port (crossport type only)

T – Tank port (single or dual types)

6 Pressure range

A – 4 to 50 bar (60 to 725 psi)

B – 4 to 100 bar (60 to 1450 psi)

F – 4 to 200 bar (60 to 2900 psi)

G – 4 to 315 bar (60 to 4500 psi)

7 Adjustment device

H – Knob adjuster

K – Micrometer knob with keylock

W – Screw with locknut

8 External drain

E – External drain

Omit for internal drain models.

9 P port acted upon

B – "B" cylinder port (dual or crossport type) Omit for single type.

10 Port drained into

A – "A" cylinder port (crossport type only)

T – Tank port (dual type only)

11 Pressure range

Omit for single type.

A – 4 to 50 bar (60 to 725 psi)

B – 4 to 100 bar (60 to 1450 psi)

F – 4 to 200 bar (60 to 2900 psi)

G – 4 to 315 bar (60 to 4500 psi)

12 Adjustment device

Omit for single relief models.

H – Knob adjuster

K – Micrometer knob with keylock

W – Screw with locknut

13 External drain

E – External drain same as position 8

Omit for single relief models.

14 Remote control port

RC – Remote control port

Not available on crossport models.

15 Gage port & thread type

Gage port for P-T models only; optional remote control (RC) and external drain (E) ports as applicable.

Omit for crossport models

B – G 1/8" (1/8" BSPF)

S – SAE-4 O-ring boss port

(0.4375-20 UNF-2B thread)

16 Design number - 30 series

Subject to change. Installation dimensions unaltered for design numbers 30 to 39 inclusive.

Functional Symbols



DGMC2-5- **AT-**-BT-**-*-30**

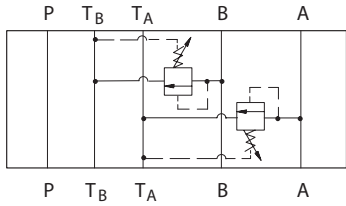

DGMC-5- **AT-**-*-30**

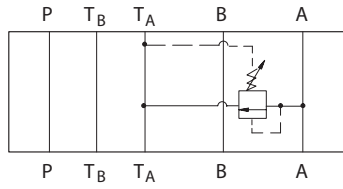

DGMC-5- **BT-**-E-**-30**

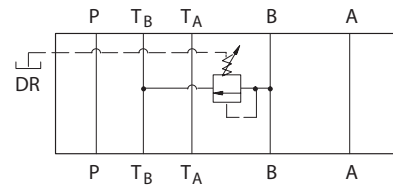

DGMC2-5- **AT-**-BT-**-RC-**-30**

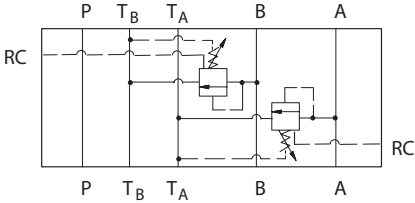

DGMC-5- **AT-**-RC-**-30**

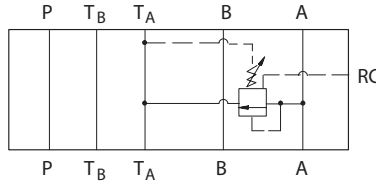

DGMC-5- **BT-**-E-RC-**-30**

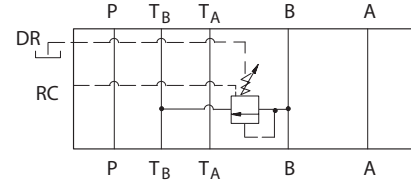

DGMC2-5- **AT-**-E-BT-**-E-**-30**

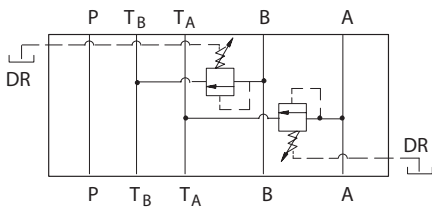

DGMC-5- **AT-**-E-**-30**

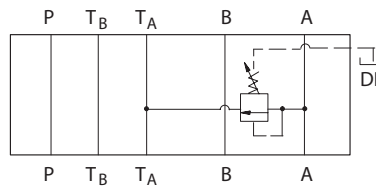

DGMC-5- **PT-**-*-30**

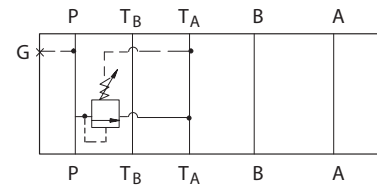

DGMC2-5- **AT-**-E-BT-**-E-RC-**-30**

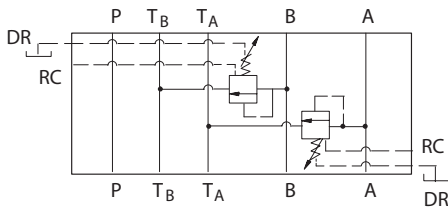

DGMC-5- **AT-**-E-RC-**-30**

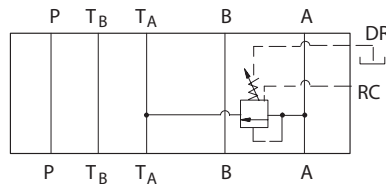

DGMC-5- **PT-**-RC-**-30**

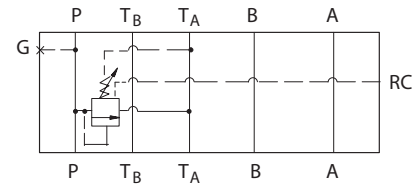

DGMC2-5- **AB-**-BA-**-30**

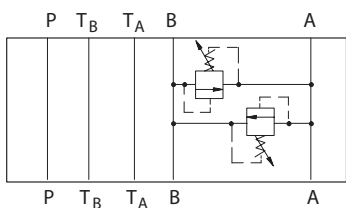

DGMC-5- **BT-**-*-30**

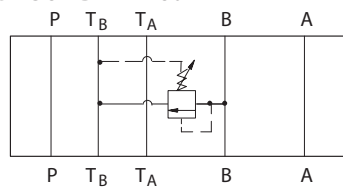

DGMC-5- **PT-**-E-**-30**

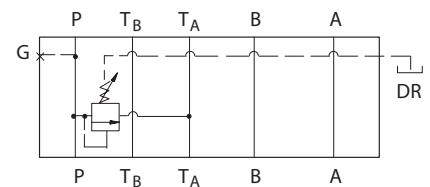

DGMC2-5- **AB-**-E-BA-**-E-**-30**

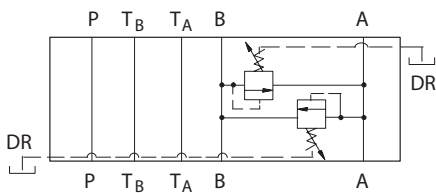

DGMC-5- **BT-**-RC-**-30**

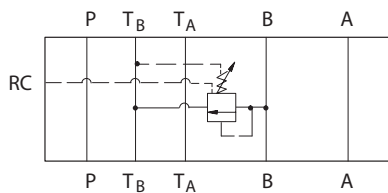

DGMC-5- **PT-**-E-RC-**-30**

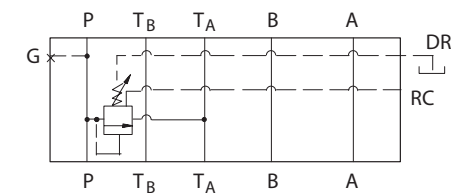

Basic Characteristics

| | |
|---|--|
| Maximum flow | 120 l/min (32 USgpm) |
| Pilot flow@ 50 °C (120 °F) and 315 bar (4500 psi) | 400–700 ml/min (24 in ³ /min-43 in ³ /min) |
| Maximum operating pressure | 315 bar (4500 psi)ar (450 psi) |
| Pressure overshoot | 31 bar (450 psi) |
| Operating temperature | -0° to 80 °C (32 ° to 180 °F) |
| Weights | DGMC 2,9 kg (6.5 lbs) DGMC2 3,6 kg (7.9 lbs) |

Response time: For conditions of 5 liters (300 in³) of oil under compression and a flow rate of 120 l/min (32 USgpm) typical response is:

| Initial pressure | Final pressure | Response time |
|------------------|--------------------|---------------|
| 17 bar (250 psi) | 35 bar (500 psi) | 95 ms |
| 35 bar (500 psi) | 140 bar (2000 psi) | 110 ms |
| 35 bar (500 psi) | 315 bar (4500 psi) | 150 ms |

Performance Data

DGMC-5 and DGMC2-5 Insertion Loss

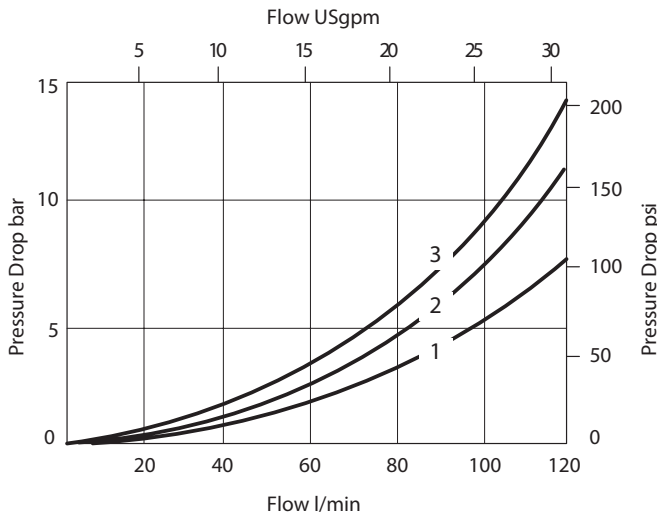

Insertion Loss

Total change in pressure drop from through ports "P" "B", "A" and "T" caused by the addition of the SystemStak valve to a hydraulic circuit. Insertion loss curves (see top left):

- DGMC2-5-AT-**-*(E)-BT-**-*(E)-(RC)*-30
DGMC-5-AT-**-*(E)-(RC)*-30
DGMC-5-BT-**-*(E)(RC)*-30
- DGMC-5-PT-**-*(E)-(RC)*-30
- DGMC2-5-AB-**-*(BA)-**-30

DGMC-5 and DGMC2-5 Pressure Override

The pressure override chart (below) shows typical override of different adjustment ranges at maximum settings.

DGMC-5 and DGMC2-5 Vented Pressure (RC models only)

(Not applicable for crossport models)

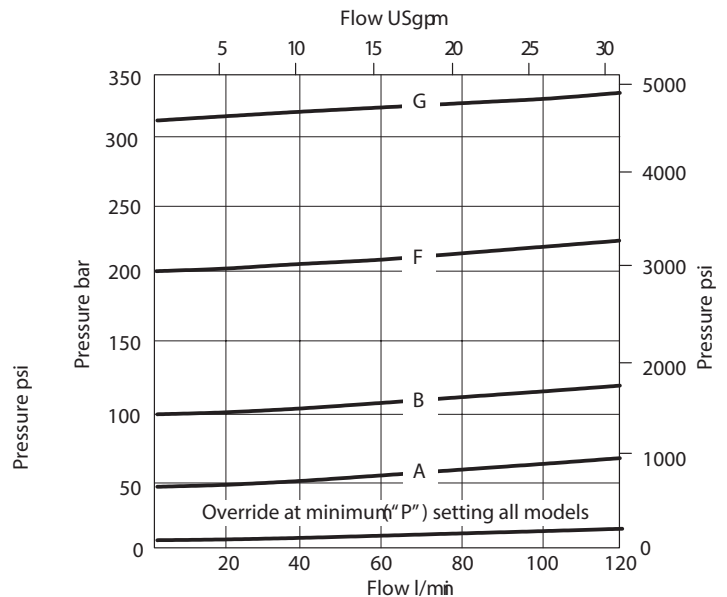
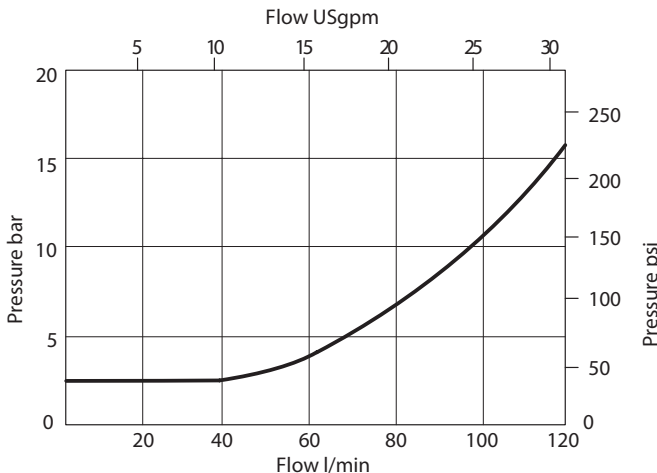

The vented pressure chart (above) indicates flow from control port to discharge port over relief element.

Installation Dimensions



DGMC-5-PT Single Relief

mm (inches)

See page 37 for optional adjustment devices.
See page 38 for interface dimensions.

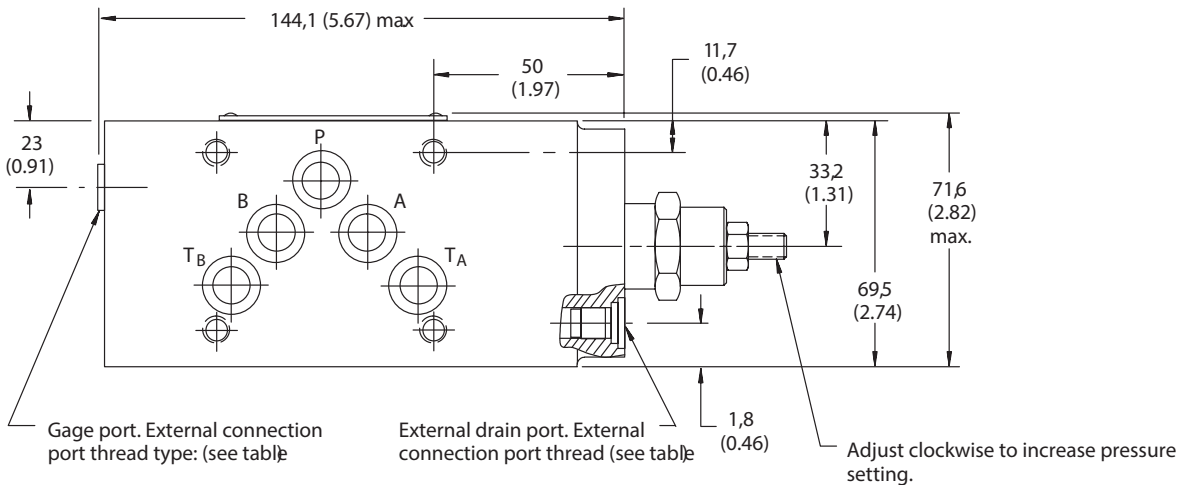
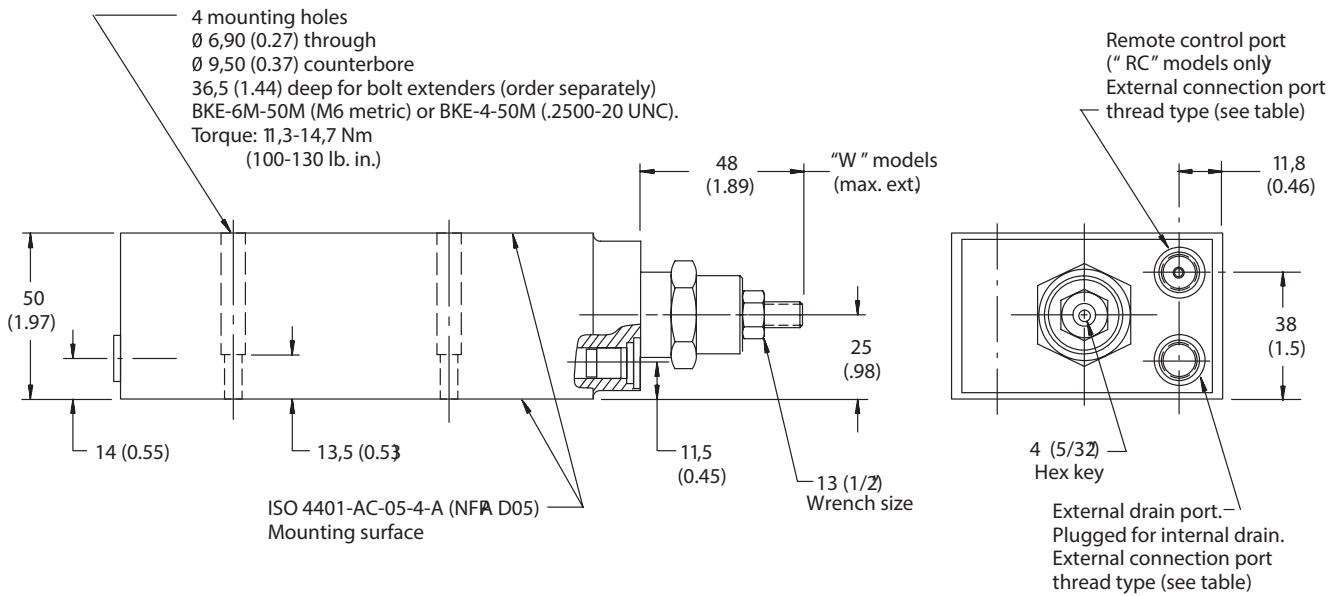

External connection port threads

"S" models - SAE-4 O-ring boss port
 (0.4375-20 UNF-2B thread).

"B" models - G 1/8 (1/8 BSPF)

Note: Back pressure in drain is added to this
 setting for internal drain models only.

Installation Dimensions



DGMC-5-BT Single Relief

mm (inches)

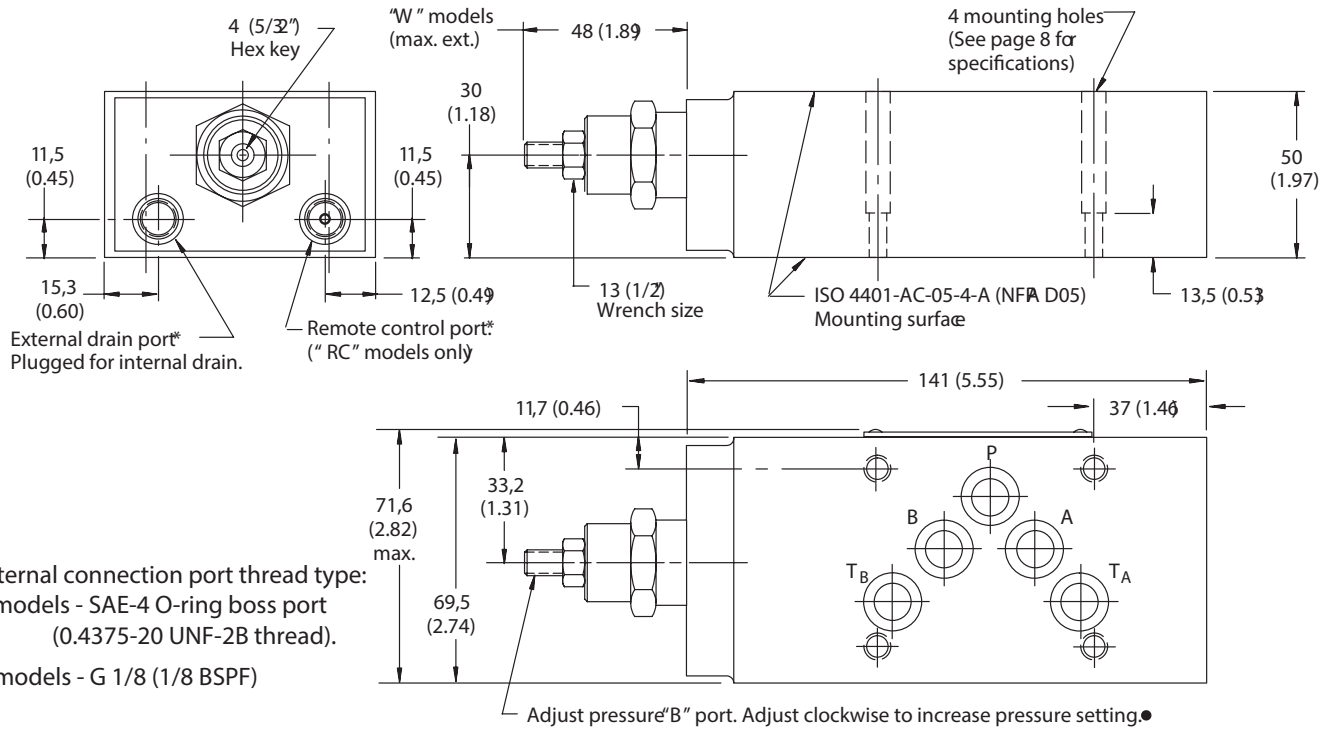

* External connection port thread type:

"S" models - SAE-4 O-ring boss port (0.4375-20 UNF-2B thread).

"B" models - G 1/8 (1/8 BSPF)

- Back pressure in drain is added to this setting for internal drain models only.

See page 37 for optional adjustment devices.
See page 38 for interface dimensions.

DGMC-5-AT Single Relief

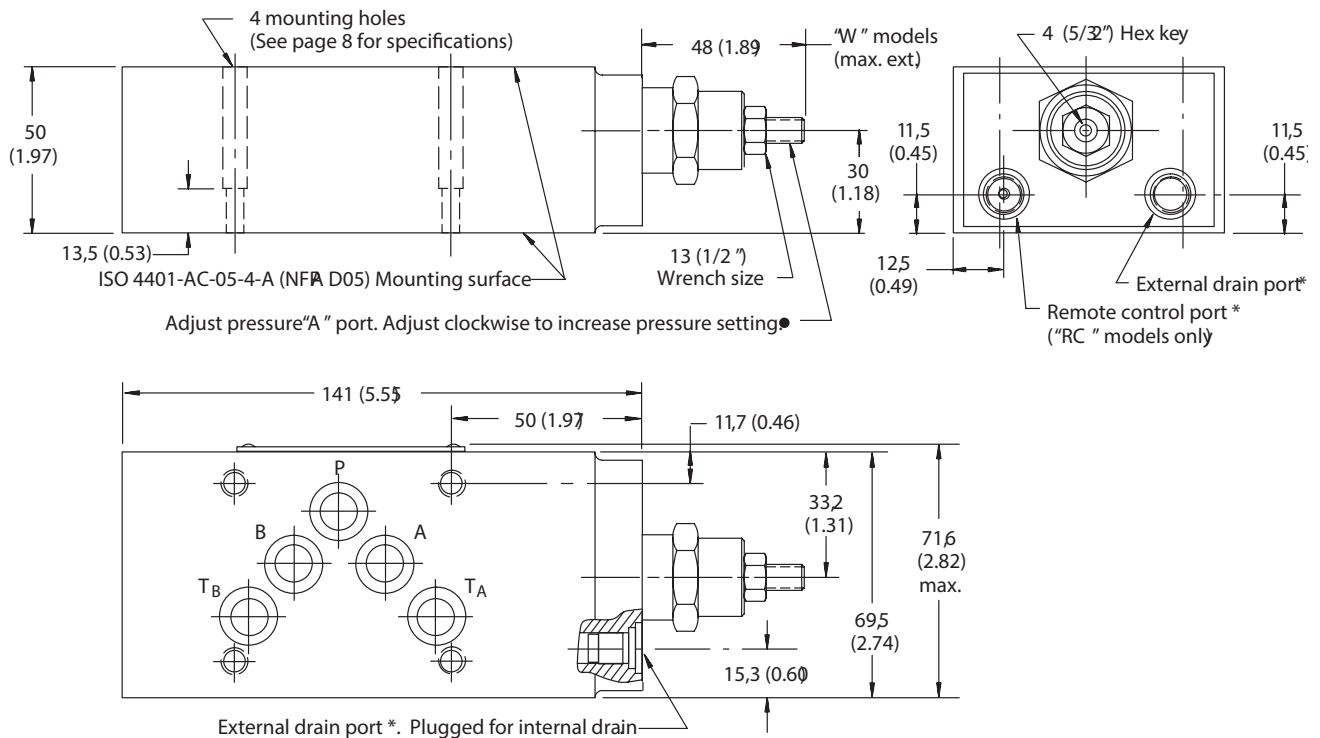

Installation Dimensions



DGMC2-5-AB-**-BA-**-30

Dual Crossport Relief

mm (inches)

See page 37 for optional adjustment devices.
See page 38 for interface dimensions.

4 mounting holes
 \varnothing 6,90 (0.27) through.
 \varnothing 9,50 (0.37) counterbore
 46,5 (1.83) deep
 for bolt extenders
 (order separately)
 BKE-6M-60M (M6 metric) or
 BKE-4-60M (.2500-20 UNC).
 Torque: 11,3-14,7 Nm
 (100-130 lb. in.)

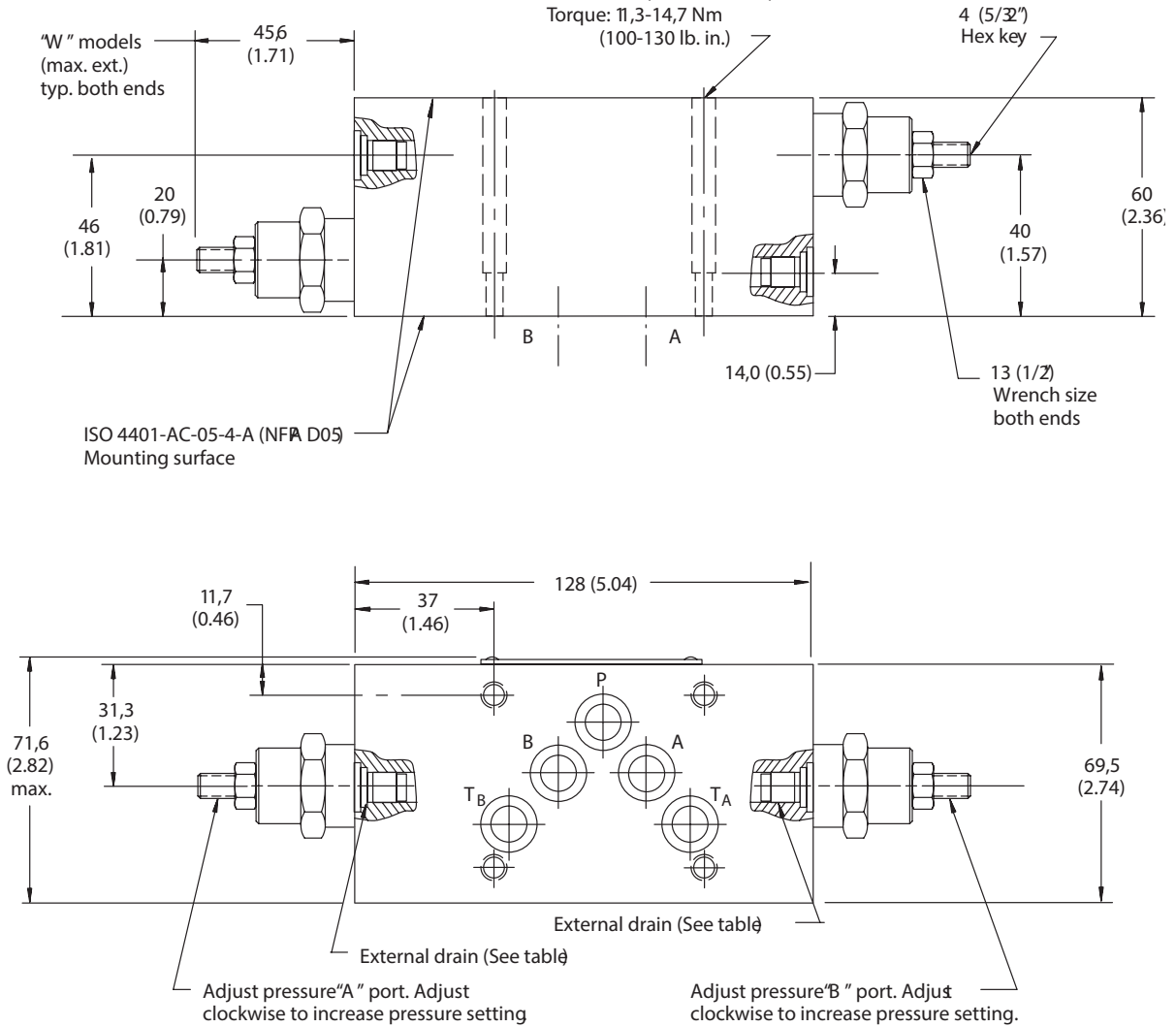

External drain port threads

"S" models - SAE-4 O-ring boss port
 (0.4375-20 UNF-2B thread).

"B" models - G 1/8 (1/8 BSPF)

Installation Dimensions



DGMC-5-AB--*(E)-*-30**
Single Crossport Relief
 mm (inches)

See page 37 for optional adjustment devices.
 See page 38 for interface dimensions.

4 mounting holes
 Ø 6,90 (0.27) through.
 Ø 9,50 (0.37) counterbore
 46,5 (1.83) deep
 for bolt extenders
 (order separately)
 BKE-6M-60M (M6 metric) or
 BKE-4-60M (.2500-20 UNC).
 Torque: 11,3-14,7 Nm
 (100-130 lb. in.)

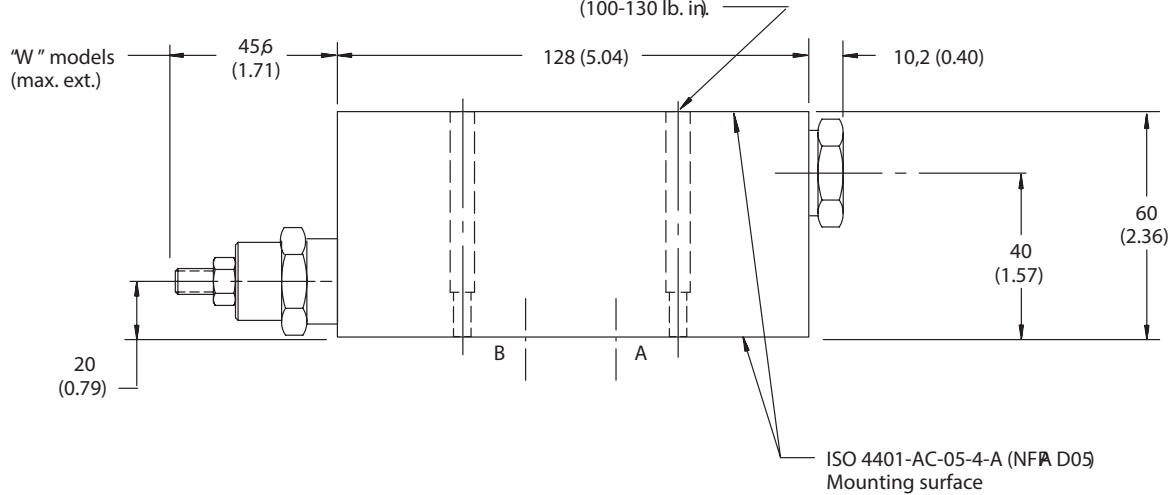

DGMC-5-BA--*(E)-*-30**
Single Crossport Relief
 mm (inches)

4 mounting holes
 (See above for specifications)

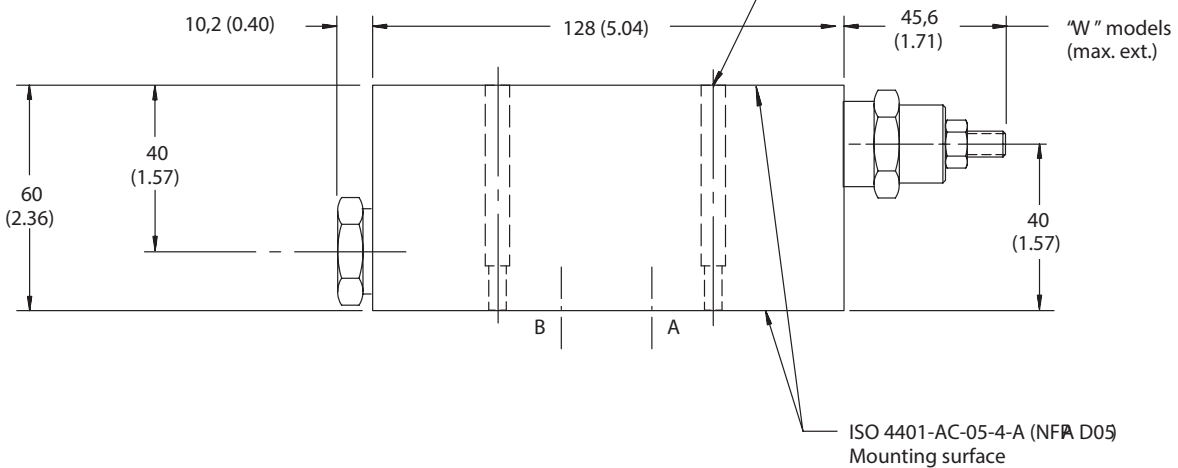

DGMX2

General Description

These two-stage spool valves maintain a reduced outlet pressure against variations in inlet pressure.

These valves are able to act as relief valves (at 50% of maximum flow) to prevent excess pressure being developed when an actuator is subject to a reactive load. Relief flow is directed to the "T_B" port. Therefore, for the relief function to operate all components above this DGMX2 module must contain the "T" port, and the directional valve must have the "T_B" bypass feature.

Pilot control may be from the "P", "A", or "B" port. Pilot drain flow may be directed internally to tank port "TA", or externally out of the valve body.

Any pressure in the line to which these valves are drained is additive to the valve pressure setting.

The valve pressure setting is adjustable by means of either an adjusting screw containing an internal hex, a hand-adjust knob, or a micrometer knob with keylock.

Different spring ratings cover an overall pressure range from 2 to 315 bar (30-4500 psi).

The metering spool element in this design is always positioned in the "P" line (see symbols on page 14). The connection of the pilot control line determines at which port the reduced pressure is obtained. For example:

"PP" pilot for reduced pressure in "P" port

"PA" pilot for reduced pressure in "A" port

"PB" pilot for reduced pressure in "B" port

The "A" and "B" line models provide for reduced pressure when "P" is connected to "A" or "B". It allows free flow through the service port when connected to "T" (all via a four-way directional valve).

Model Code

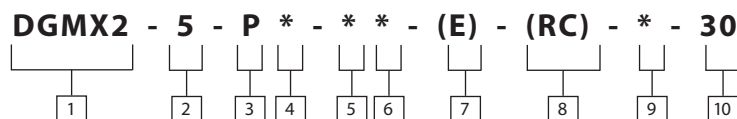

1 Valve function

Manifold or subplate mounted reducing/relieving valve.

2 Interface

5 – ISO 4401-AC-05-4-A, CETOP 5
RP35A size 5 ANSI/NFPA D05

3 Port operated upon

P – Pressure port

4 Pilot control

A – Cylinder port A
B – Cylinder port B
P – Pressure port

5 Pressure range

A – 2,0 to 50 bar (30 to 725 psi)
B – 8,5 to 100 bar (125 to 1450 psi)
F – 8,5 to 200 bar (125 to 2900 psi)
G – 8,5 to 315 bar (125 to 4500 psi)

6 Adjustment device

H – Knob adjuster
K – Micrometer knob with keylock
W – Screw with locknut

7 External drain

E – External drain
Omit for internal drain models.

8 Remote control

Omit if not required.

9 Gage port & thread type

Gage port (all models), external drain (E)
B – G 1/8" (1/8" BSPF)
S – SAE-4 O-ring boss port
(0.4375-20 UNF-2B thread)

10 Design number - 30 series

Subject to change. Installation dimensions unaltered for design numbers 30 to 39 inclusive.

Functional Symbols



DGMX2-5- **PP** -**-*-30

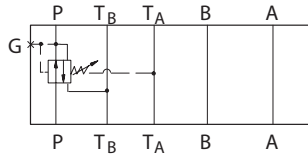

DGMX2-5- **PA** -**-*-30

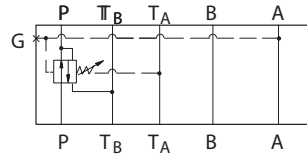

DGMX2-5- **-PB** -**-*-30

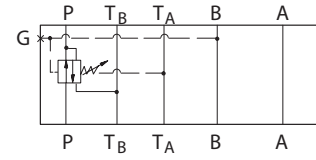

DGMX2-5- **PP** -**-**E** -*-30

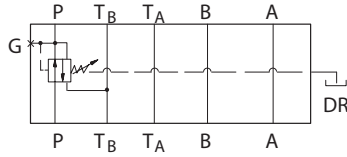

DGMX2-5- **PA** -**- **E** -30

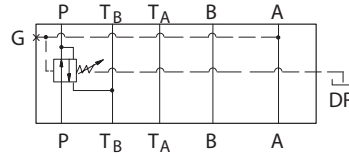

DGMX2-5- **-PB** -**- **E** -30

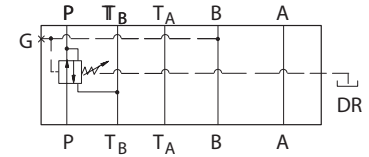

DGMX2-5- **PP** -**- **RC** -*-30

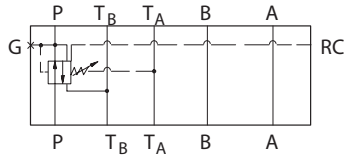

DGMX2-5- **PA** -**- **RC** -*-30

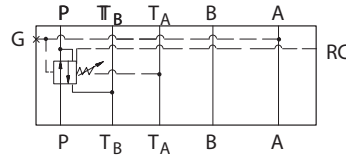

DGMX2-5- **-PB** -**- **RC** -*-30

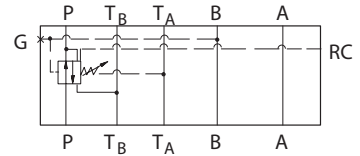

DGMX2-5- **PP** -**- **E-RC** -*-30

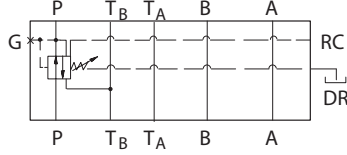

DGMX2-5- **PA** -**- **E-RC** -30

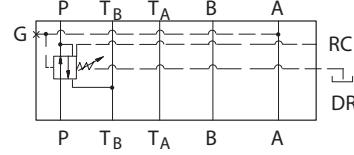

DGMX2-5- **-PB** -**- **E-RC** -30

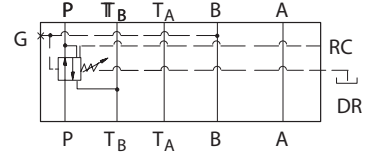

Basic Characteristics

| | |
|--|---|
| Maximum flow | 120 l/min (32 USgpm) |
| Pilot flow @ 50 °C (120 °F) and 315 bar (4500 psi) | 290–420 ml/min (18 in ³ /min–26 in ³ /min) |
| Maximum operating pressure | "A" models - 70 bar (1000 psi) * (inlet pressure) 50 bar (725 psi) (reduced pressure) "B", "F" & "G" models - 315 bar (4500 psi) |
| Leakage flow rate @ 50 °C (120 °F) and 315 bar (4500 psi) | 80–200 ml/min (15–12 in ³ /min) |
| (Leakage to "Tb" around spool land @315 bar (4500 psi) Operating temperature | -0° to 80 °C (32 ° to 180 °F) |
| Weights | 3,5 kg (7.7 lbs) |

* Slightly higher pressure override characteristics between 70 bar (1000 psi) and 315 bar (4500 psi) inlet.

Performance Data

DGMX2 Insertion Loss

These curves show the typical pressure drop for each flow path in the valve. The "P" port pressure drop is the pressure drop for flow across the reducing valve spool in the fully open condition. The total insertion loss for the valve must be calculated by summing the losses through each of the four flow paths.

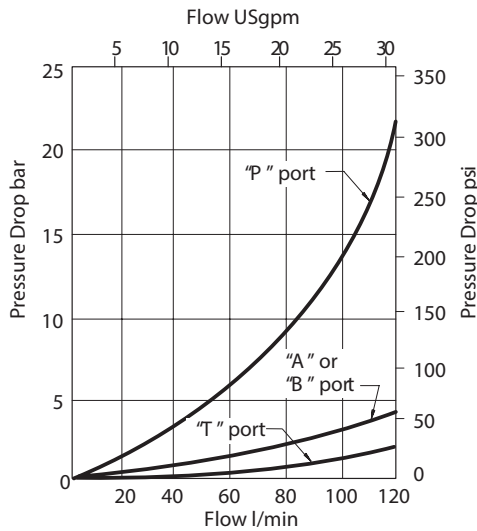

DGMX2 Pressure Override

These curves show the typical roll off or underide of the different pressure ranges at maximum settings. Also shown is the typical override of the relieving feature which prevents undesirable pressure rise in the reduced pressure port.

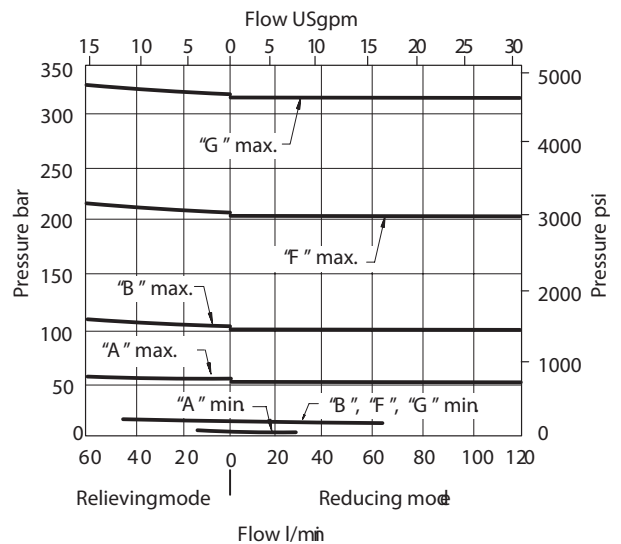

DGMX2 Minimum Reduced Pressure

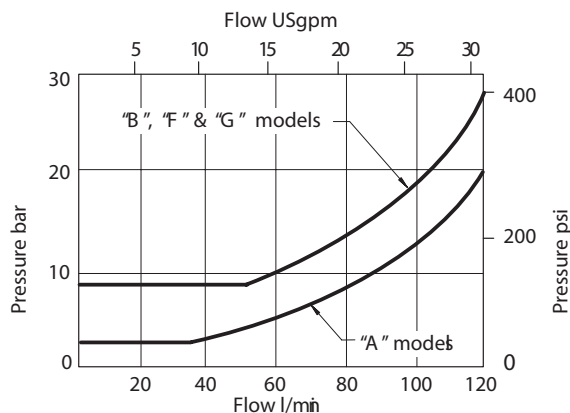

The curves (left) show the minimum reduced pressure settings allowable for a given flow rate. The minimum pressure setting applies regardless of inlet pressure. Operation of the valve below minimum settings may cause erratic valve operation due to insufficient spring force to counter flow forces acting on the spool.

Installation Dimensions



DGMX2-5-PA/PB/PP Reducing/Relieving Valves mm (inches)



See page 37 for optional adjustment devices.
See page 38 for interface dimensions.

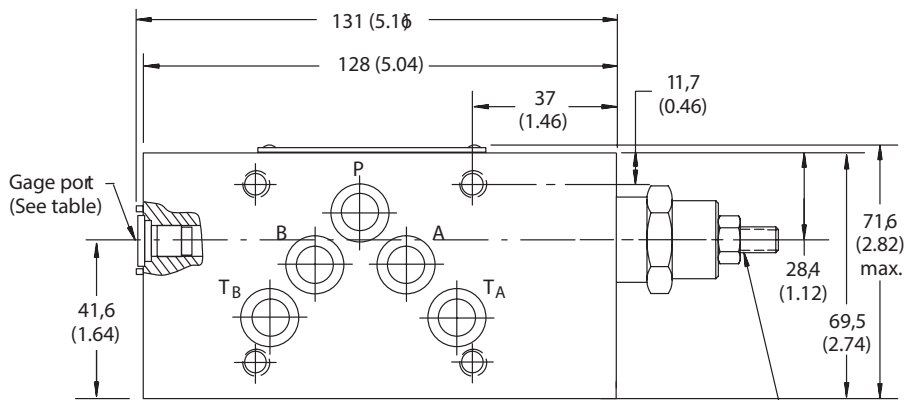
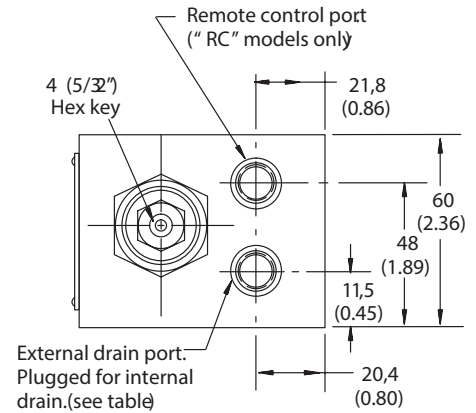
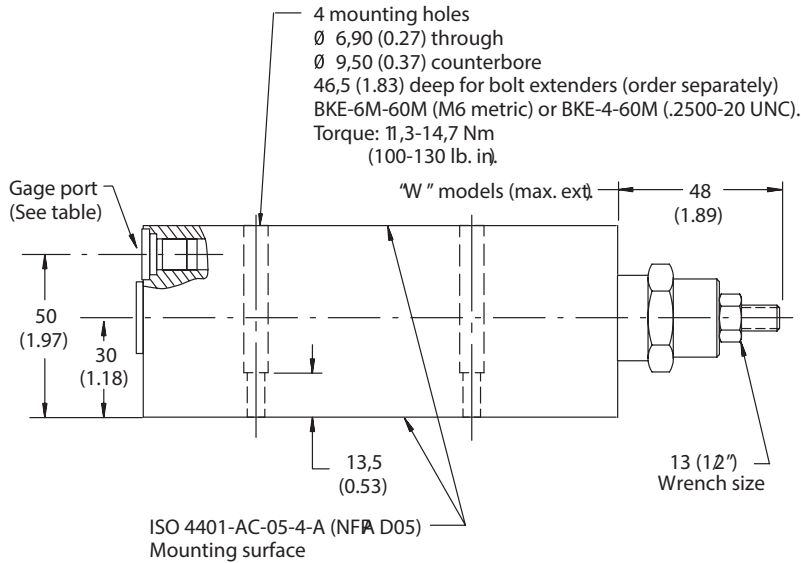

Adjust clockwise to increase
pressure setting.
Note: Back pressure in drain
is added to this setting fo
internal drain models only.

External connection port threads

"S" models - SAE-4 O-ring boss port
(0.4375-20 UNF-2B thread).

"B" models - G 1/8 (1/8 BSPF)

DGMR1

General Description

These two-stage pressure operated valves are normally closed to flow through the main spool flow path. When system pressure reaches or exceeds the valve setting, the main spool flow path opens. Pilot flow may be externally or internally drained to tank.

Any pressure in the line to which these valves are drained is additive to the valve pressure setting.

The valve pressure setting is adjustable by means of either an adjustable screw containing an internal hex, a hand-adjust knob, or a micrometer knob with keylock. Different spring ratings cover an overall pressure range from 5 to 315 bar (75-4500 psi).

Model Code

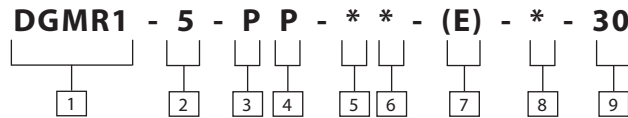

1 Valve function

Manifold or subplate mounted sequence valve.

2 Interface

5 – ISO 4401-AC-05-4-A, CETOP RP35H
Size 5 ANSI/NFPA D05

3 Port operated upon

P – Pressure port

4 Pilot control

P – Pressure port

5 Pressure range

A – 5 to 50 bar (75 to 725 psi)
B – 5 to 100 bar (75 to 1450 psi)
F – 5 to 200 bar (75 to 2900 psi)
G – 5 to 315 bar (75 to 4500 psi)

6 Adjustment device

H – Knob adjuster
K – Micrometer knob with keylock
W – Screw with locknut

7 External drain

E – External drain
Omit for internal drain models.

8 Gage port & thread type

Gage port (all models), external drain (E) (optional).
B – G 1/8" (1/8" BSPF)
S – SAE-4 O-ring boss port
(0.4375-20 UNF-2B thread)

9 Design number - 30 series

Subject to change. Installation dimensions unaltered for design numbers 30 to 39 inclusive.

Functional Symbols

DGMR1-5- PP-**-*-30

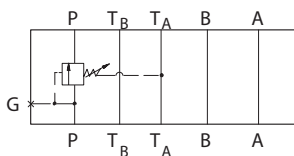

DGMR1-5- PP-**-E-*-30

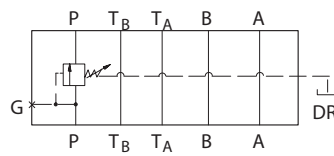

Basic Characteristics

| | |
|---|--|
| Maximum flow | 120 l/min (32 USgpm) |
| Pilot flow @ 50 °C (120 °F) and 315 bar (4500 psi) | 400-500 ml/min (24-31 in ³ /min) |
| Maximum operating pressure | "A" models - 70 bar (1000 psi) * (inlet pressure) 50 bar (725 psi) (reduced pressure) "B", "F" & "G" models - 315 bar (4500 psi) |
| Leakage flow rate @ 50 °C (120 °F) and 315 bar (4500 psi) | 80-200 ml/min (15-12 in ³ /min) |
| Operating temperature | -0° to 80 °C (32° to 180 °F) |
| Weights | 3,5 kg (7.7 lbs) |

Performance Data

Insertion Losses

These curves show the typical pressure drop for each flow path in the valve. The "P" port pressure drop is the pressure drop for flow across the sequence valve spool in the fully open position.

The total insertion loss for the valve must be calculated by summing the losses through each of the four flow paths.

Pressure Override

Typical pressure override of the different pressure ranges at minimum and maximum settings.

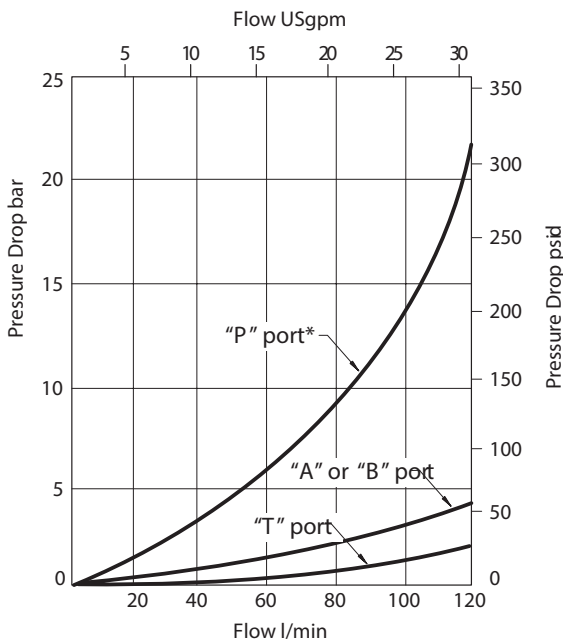

*Spool held in open position

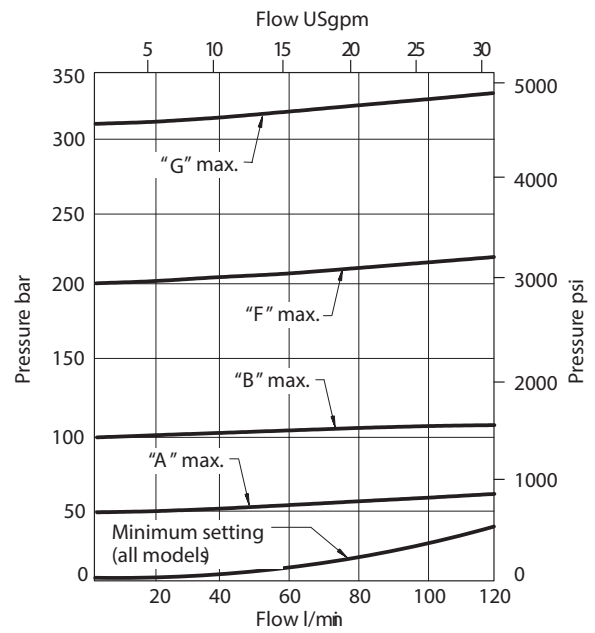

Installation Dimensions



DGMR1-5-PP--30**

Sequence Valve

mm (inches)

See page 37 for optional adjustment devices.

See page 38 for interface dimensions.

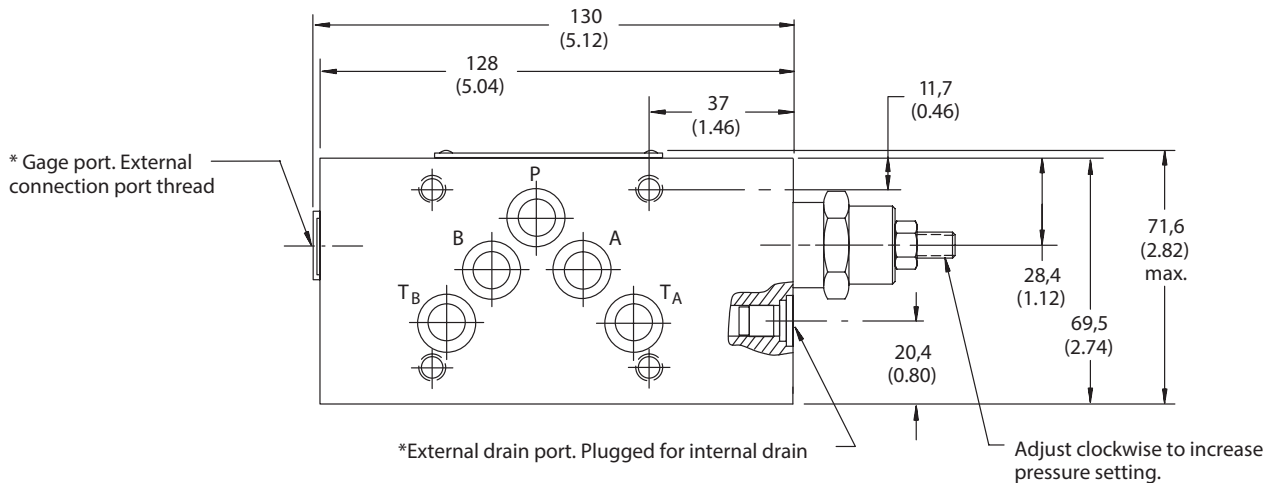
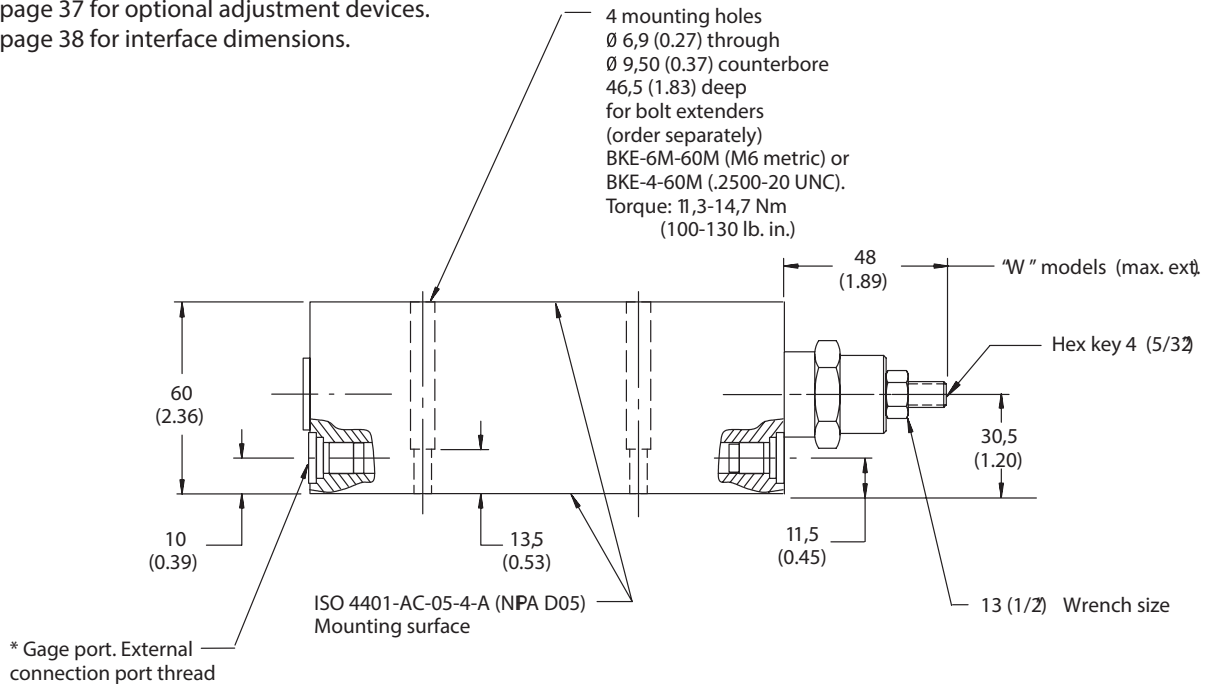

*External drain and gage port threads

"S" models - SAE-4 O-ring boss port
 (0.4375-20 UNF-2B thread).

"B" models - G 1/8 (1/8 BSPF)

Note: Back pressure in drain is added to this setting for internal drain models only.

SystemStak™ Counterbalance Valves

DGMR

General Description

Danfoss SystemStak counterbalance valves provide continuous protection from pump cavitation and prevent an actuator from running ahead of the pump supply.

These valves also provide thermal relief protection in closed systems.

NOTE

Counterbalance valves adjust in the opposite direction of other pressure control valves. Turning the adjuster counterclockwise increases the valve setting. Turning the adjustment clockwise lowers the pressure setting, releasing the load.

Drain

Any pressure in the line to which these valves are drained is additive to the valve pressure setting.

Pilot pressure Calculation

To open the counterbalance valve by remote control (referring to functional symbols below):

For 4:1 ratio (typically for cylinder load control), nominal pilot pressure at Port B =

$$\frac{\text{Cracking pressure} + (5 \times \text{Port } A_1 \text{ pressure}) - \text{Port A pressure}}{4}$$

For 10:1 ratio (typically for hydraulic motor control), nominal pilot pressure at Port B =

$$\frac{\text{Cracking pressure} + (11 \times \text{Port } A_1 \text{ pressure}) - \text{Port A pressure}}{10}$$

Model Code

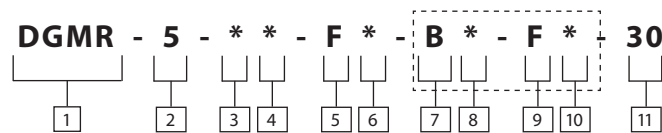

1 Valve function

Manifold or subplate mounted counterbalance valve.

2 Interface

5 – ISO 4401-AC-05-4-A, CETOP 5
RP35H, Size 5 ANSI/NFPA D05

3 Port operated upon

A – Counterbalance in A, piloted from B
B – Counterbalance in B, piloted from A

4 Pilot ratio

1 – 4:1
2 – 10:1

5 Pressure range

F – 60 to 210 bar (900 to 3000 psi)

6 Adjustment device

H – Knob adjuster
C – Cap over screw
W – Screw with locknut

7 Port acted upon

(Omit for single type.)
B – Counterbalance in B, piloted from A

8 Pilot ratio

(Omit for single type.)
1 – 4:1
2 – 10:1

9 Pressure range

(Omit for single type.)
F – 60 to 210 bar (900 to 3000 psi)

10 Adjustment device

(Omit for single type.)
H – Knob adjuster
C – Cap over screw
W – Screw with locknut

11 Design number - 30 series

Subject to change. Installation dimensions unaltered for design numbers 30 to 39 inclusive.

Functional Symbols

DGMR-5-A*-FW-B*-FW -30

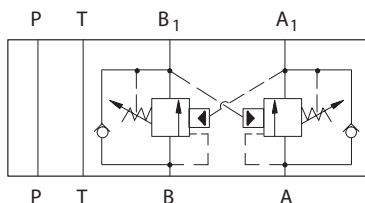

DGMR-5-A*-FW-30

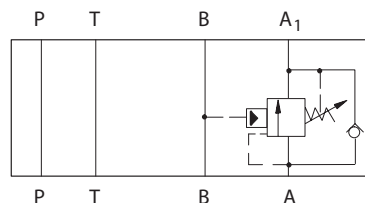

DGMR-5-B*-FW-30

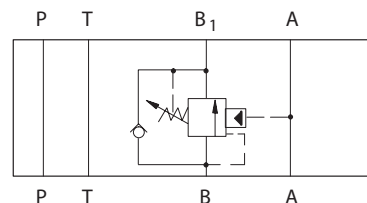

Basic Characteristics

| | |
|---|--|
| Maximum flow | 120 l/min (32 USgpm) |
| Load holding leakage @70% of pressure setting | 0.35 ml/min. |
| Cracking Pressure Adjustment Range | 60-210 bar (900-3000 psi) |
| Pilot Ratios | 4:1, 10:1 |
| Maximum operating pressure | 315 bar (4500 psi) |
| Leakage flow rate @ 50° C (120° F) and 315 bar (4500 psi) | 5 drops/min, Port A to Port A ₂ , at 70% of crack setting |
| Operating temperature | -40° to 80°C (-40° to 180°F) |
| Weights | 4,5 kg (10 lbs) |

Performance Data

DGMR Performance Curves

Insertion Losses

These curves show the typical pressure drop for each flow path in the valve for fluid viscosity range 21-32 cSt (100-150 SSU).

The total insertion loss for the valve is calculated by summing the losses through each of the four flow paths.

1. "P" port for all models.
"A" port of DGMR-5-B*-30
"B" port of DGMR-5-A*-30
2. "T" port for all models.
3. Free flow through service port of counterbalance.
4. Piloted port open through service port of counterbalance.

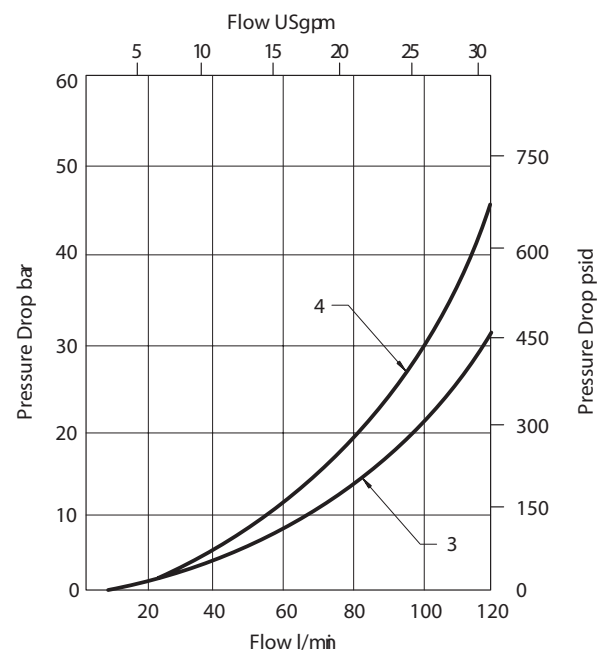
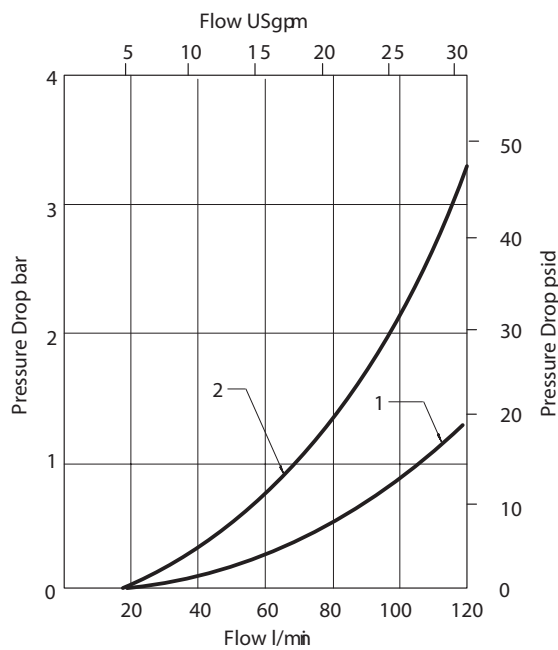

Installation Dimensions



DGMR-5-A*-FW-B*-FW-30
Dual Counterbalance on A & B Ports
 mm (inches)



See page 37 for optional adjustment devices.
 See page 38 for interface dimensions.

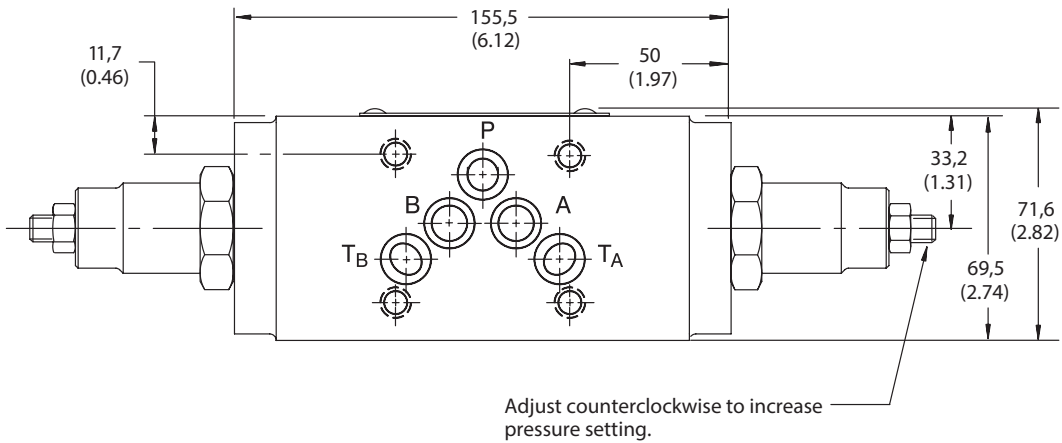
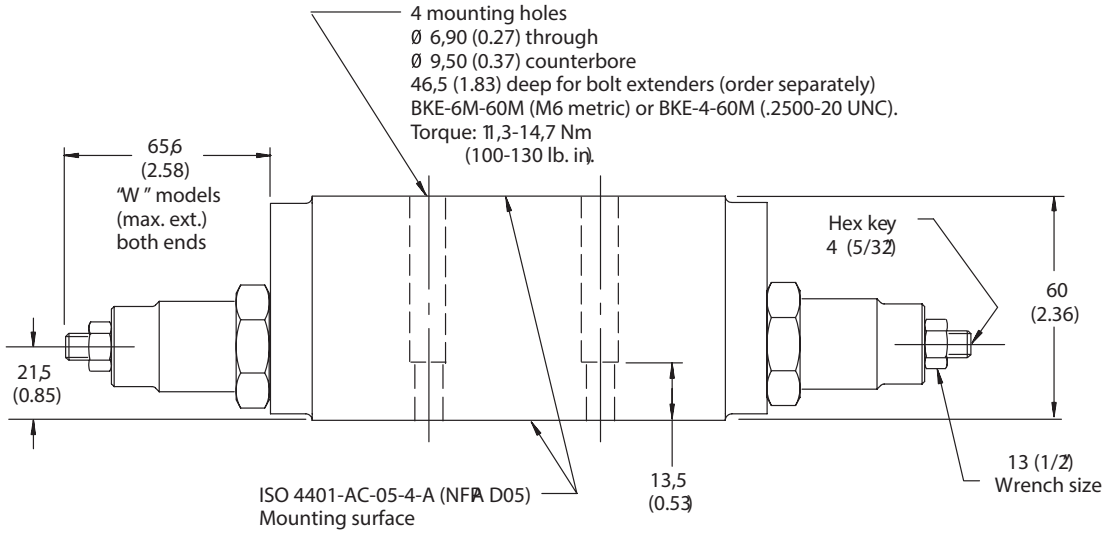

Installation Dimensions



DGMR-5-A*-FW-30 Counterbalance Port A, Piloted from B mm (inches)

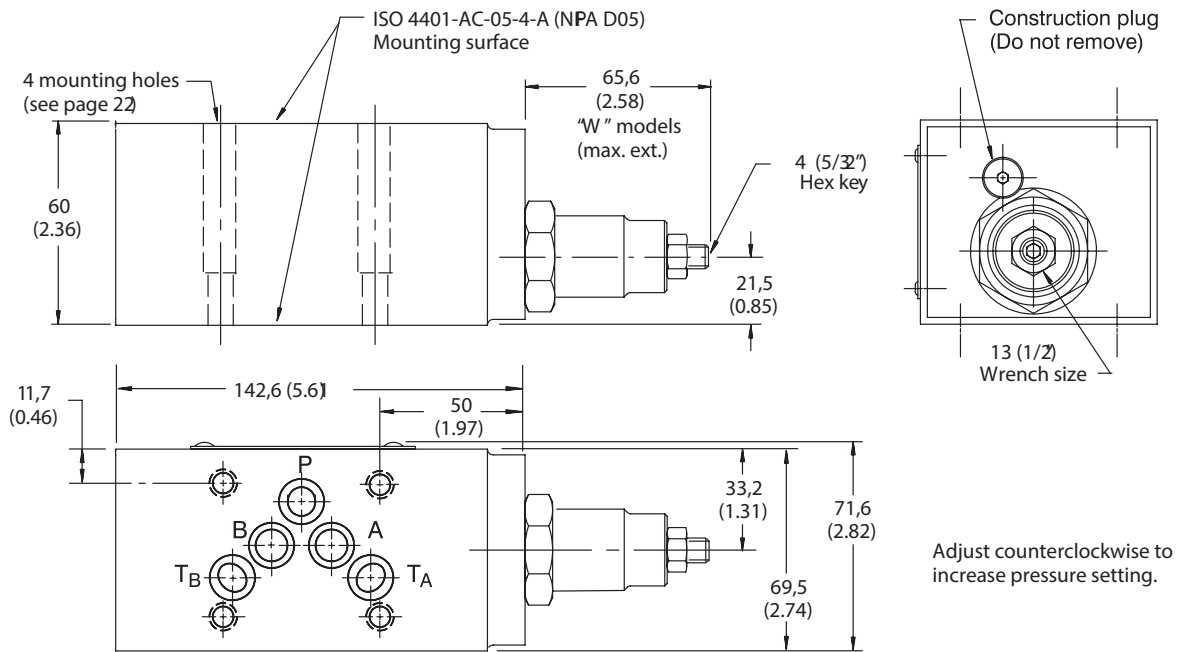

See page 37 for optional adjustment devices.
See page 38 for interface dimensions.

DGMR-5-B*-FW-30 Counterbalance Port B, Piloted from A

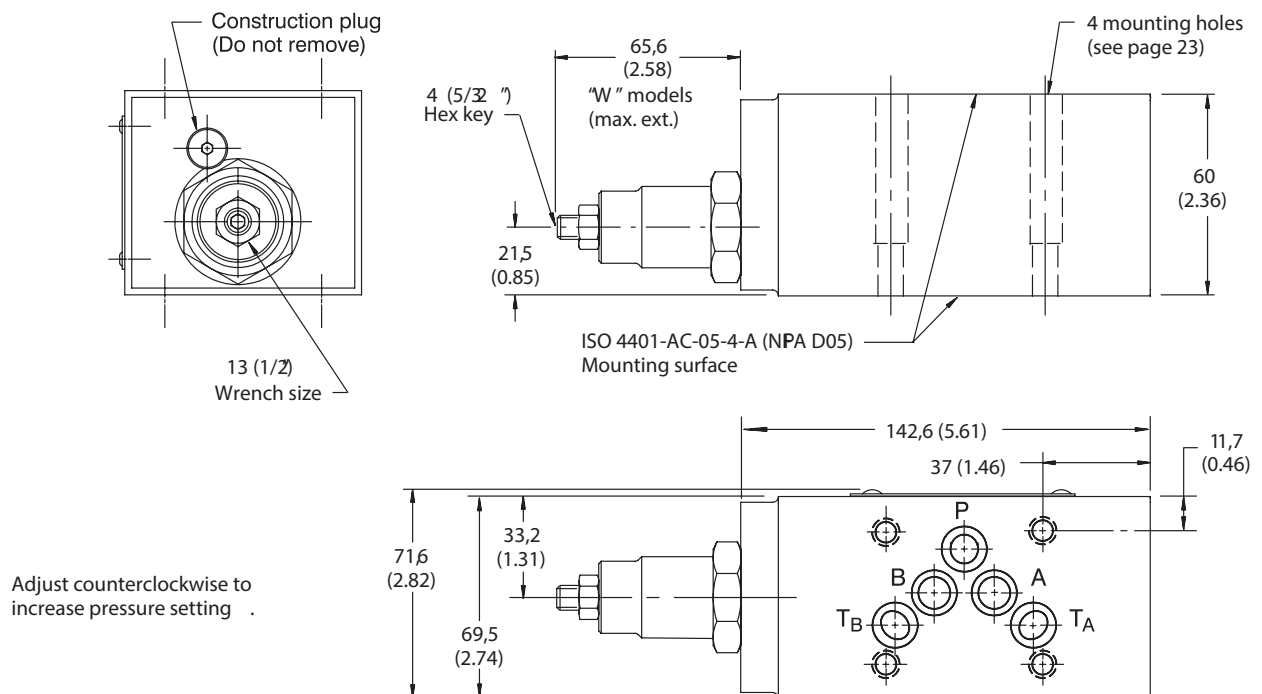

DGMFN

General Description

These valves are adjustable, non-compensated flow restrictors. An integral check valve around the regulating orifice allows free flow in one direction and metered flow in the other.

Control is available in "A" only, "B" only, and "A" and "B" ports as an "X" type (meter-in) or "Y" type (meter-out).

The "P" port is available only in the "X" type (meter-in) and does not contain a reverse flow check.

The valve flow setting is adjustable by means of either a hex key adjusting screw and locknut, a hand-adjust knob, or a micrometer knob with keylock.

A normal or fine metering capability is available. See the pressure drop curves on page 26 for detailed performance difference.

Model Code

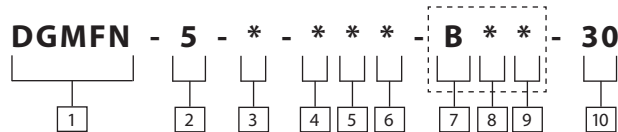

1 Valve function

Manifold or subplate mounted flow control valve.

2 Interface

5 – ISO 4401-AC-05-4-A, CETOP 5 Size
5 RP35H ANSI/NFPA D05

3 Direction of flow

X – Meter-in
Y – Meter-out

4 Port operated upon

A – Cylinder port "A" (single or dual type)
B – Cylinder port "B" (single type only)
P – Pressure port (single type only)

5 Adjustment range

1 – Fine control
2 – Normal control

6 Adjustment device

H – Knob adjuster
K – Micrometer knob with keylock
W – Screw with locknut

7 Port operated upon: second function

(Omit for single flow control models.)
B – B cylinder port (Dual type)

8 Adjustment range: second function

(Omit for single flow control models.)
1 – Fine control
2 – Normal control

9 Adjustment device: second function

(Omit for single flow control models.)
H – Knob adjuster
K – Micrometer knob with keylock
W – Screw with locknut

10 Design number - 30 series

Subject to change. Installation dimensions unaltered for design numbers 30 to 39 inclusive.

DGMFN-5- X-P**-30

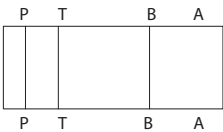

DGMFN-5- X-A**-B**-30

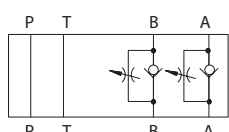

DGMFN-5- X-A**-30

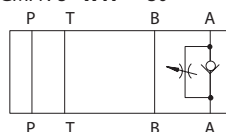

DGMFN-5- X-B**-30

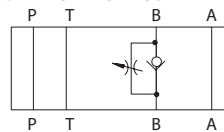

DGMFN-5- Y-A**-B**-30

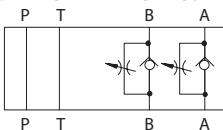

DGMFN-5- Y-A**-30

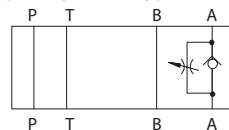

DGMFN-5- Y-B**-30

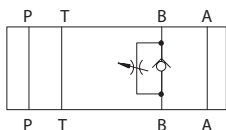

Basic Characteristics

| | |
|----------------------------|----------------------------|
| Maximum flow | 120 l/min (32 USgpm) |
| Maximum operating pressure | 315 bar (4500 psi) |
| Operating temperature | 20° to 50°C (70° to 120°F) |
| Weights | 3,1 kg (7 lbs) |

Performance Data

Minimum Controlled Flow/No-Flow Leakage

Internal leakage will vary from valve to valve and with the pressure differential across the check. Approximate levels are:

| Pressure Drop bar (psi) | Leakage* cc/min (in3/min) |
|----------------------------|------------------------------|
| 50 (725) | 160 (9.5) |
| 100 (1450) | 320 (19) |
| 200 (2900) | 640 (38) |
| 315 (4500) | 990 (60) |

* Equals minimum controllable flow rate at the pressures stated.

Pressure Drop

The curves below show the pressure drop through individual flow passages. Curves labeled "metered flow/pressure drop" refer to the pressure drop through only the passage containing the flow control regulating orifice. Total valve insertion loss is a value derived from graph 1 or 2 plus the appropriate values of lines 1, 2 and 3 from graph 3.

Graph 1

Metered flow pressure drop.
Normal adjustment – "2"
models (see model code,
page 24).

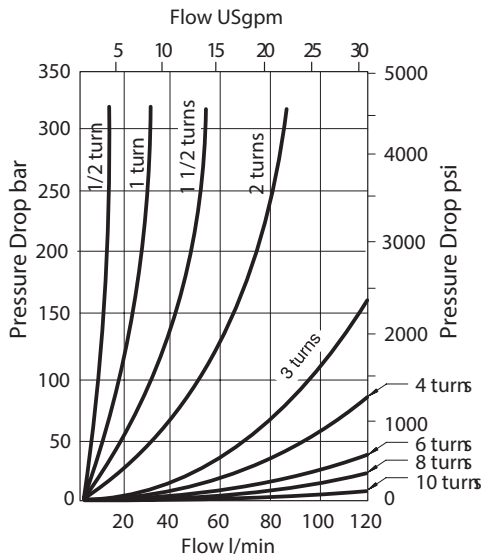

Graph 2

Metered flow pressure drop.
Fine adjustment – "1" models
(see model code, page 24).

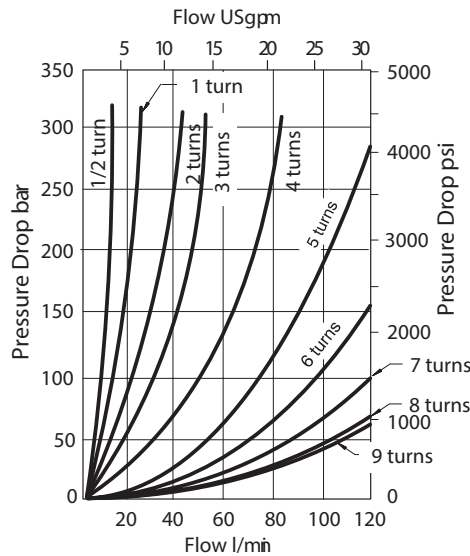

Graph 3

Free flow pressure drop across
check valve.

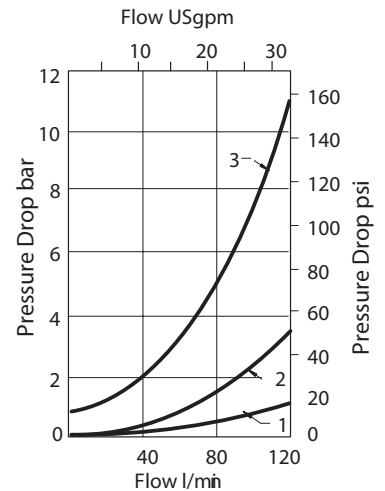

Graph 3

- 1 – "P" port of all models except DGMFN-5-X-P**-30
"B" and "T" ports of DGMFN-5-X-P**-30
- 2 – "T" port of all models except DGMFN-5-X-P**-30
"A" ports of DGMFN-5-X-P**-30
- 3 – Pressure drop across reverse free flow check valve

Note: "Turn" or "Turns" on curves in graphs 1 and 2, above, refer to turn of adjustment device from fully closed position.

Installation Dimensions



DGMFN-5-X-P & DGMFN-5-Y-A

Single Flow Controls

mm (inches)



4 mounting holes \varnothing 6,9 (0.27) through
 \varnothing 9,50 (0.37) counterbore 36,5 (1.44) deep
 for bolt extenders (order separately)
 BKE-6M-50M (M6 metric) or
 BKE-4-50M (.2500-20 UNC).
 Torque: 11,3-14,7 Nm (100-130 lb. in.)

| Model | A | B |
|-------------|-------------|-------------|
| DGMFN-5-X-P | 60,4 (2.38) | 28,4 (1.12) |
| DGMFN-5-Y-A | 52,7 (2.07) | 33,2 (1.31) |

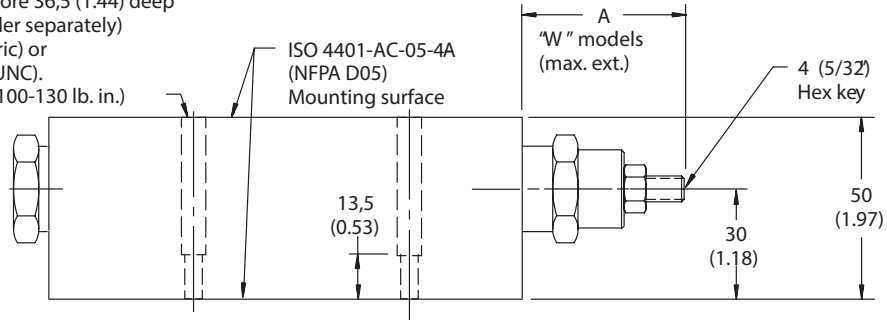

No hex plug on DGMFN-5-X-P models

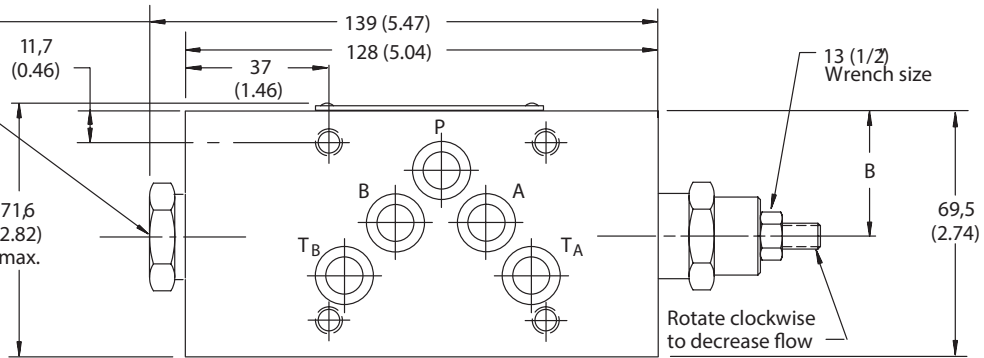

See page 37 for optional adjustment devices.

See page 38 for interface dimensions.

DGMFN-5-X-A

Single Flow Control

mm (inches)

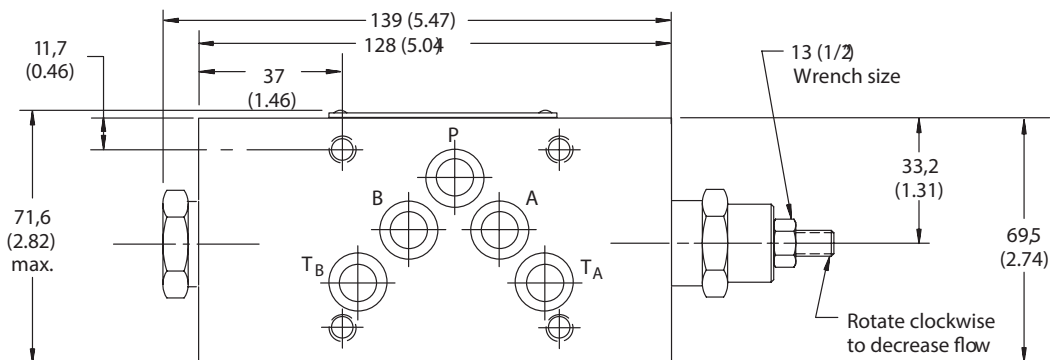
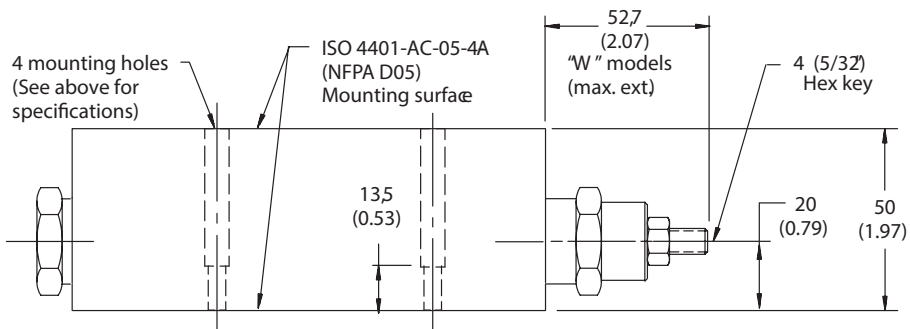

Installation Dimensions



DGMFN-5-X-B Single Flow Control mm (inches)

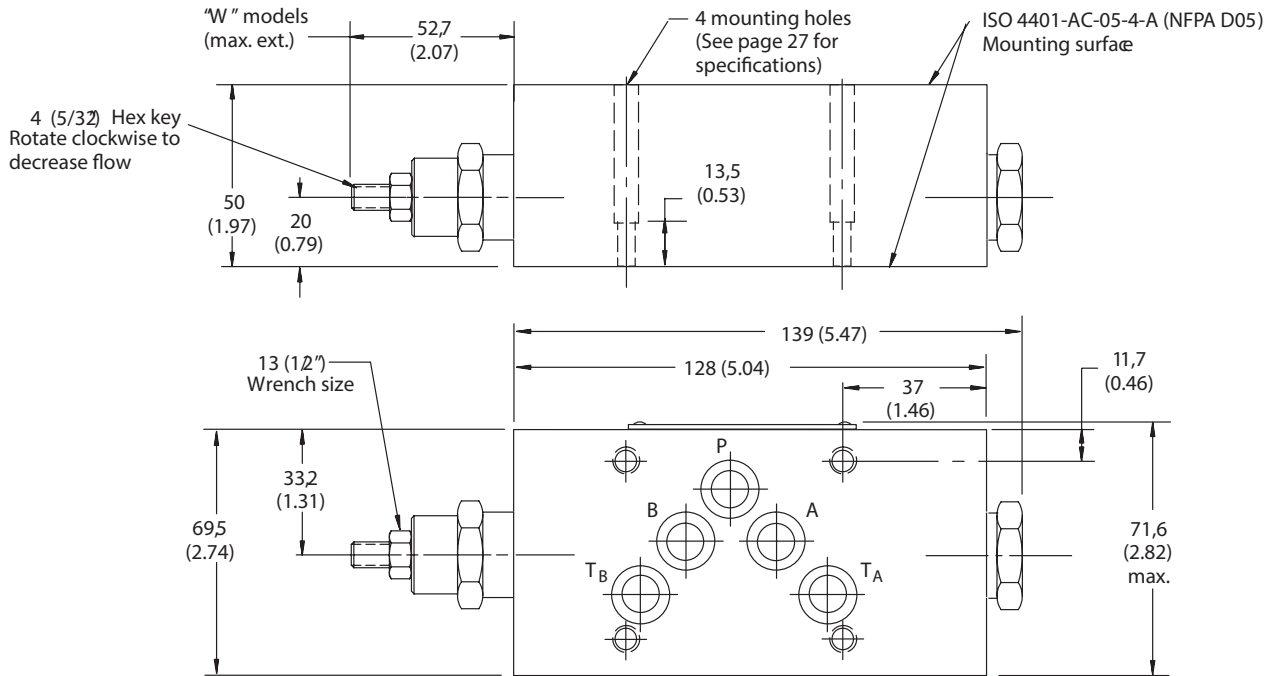

See page 37 for optional adjustment devices.
See page 38 for interface dimensions.

DGMFN-5-Y-B Single Flow Control

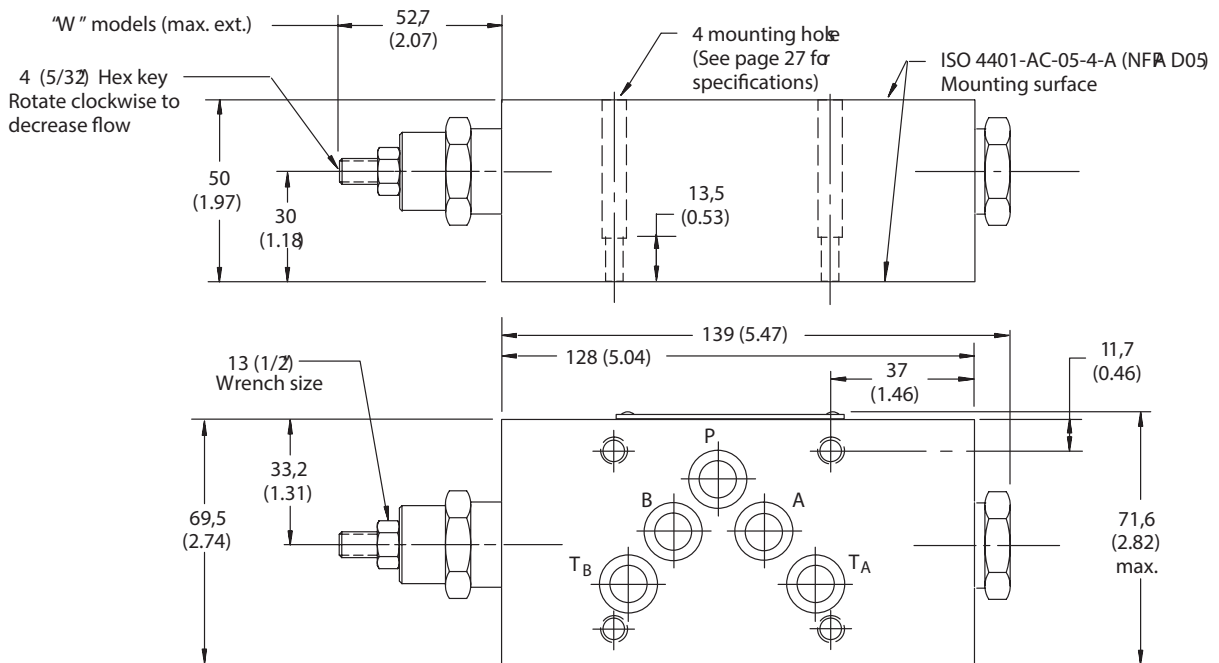

Installation Dimensions



DGMFN-5-Y Dual Flow Control

mm (inches)

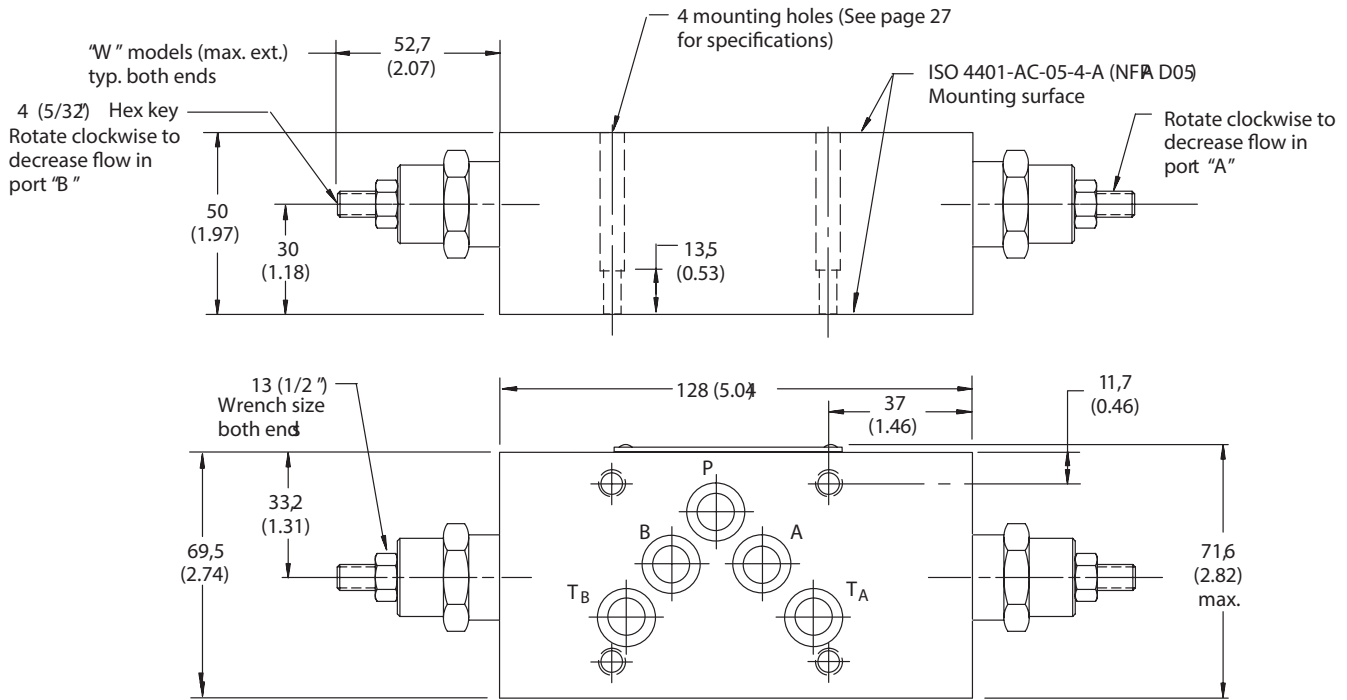

See page 37 for optional adjustment devices.

See page 38 for interface dimensions.

DGMFN-5-X Dual Flow Control

mm (inches)

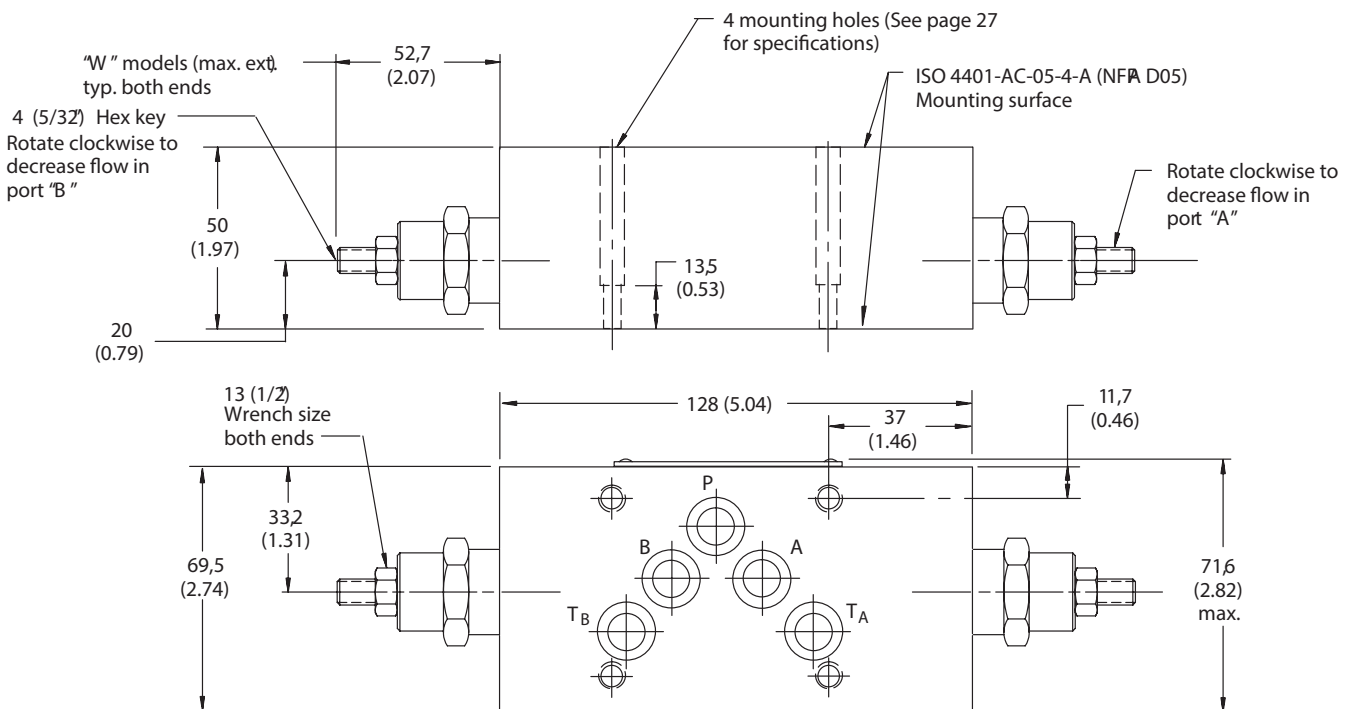

DGMPC

General Description

These valves are single or dual check units. Dual check units have identical check elements located in the "A" and "B" cylinder port lines. The check valve poppets are moved into the open position by a central pilot control spool which moves toward one check or the other, depending on which port is pressurized.

The check valve located in the return circuit is opened by the operating pressure in the primary circuit. When the pressure in the pilot line is vented, the check valve will remain closed.

The pilot spool area to valve seat ratio is 3:1 on standard models, and 20:1 on models with the decompression feature.

Check valve cracking (opening) pressures of 1 bar (15 psi), 2,5 bar (36 psi) and 5 bar (73 psi) are available. Please note that back pressure on the downstream or free-flow side of the pilot check valve may prevent the valve from opening in certain situations. (Back pressure opposes pilot pressure trying to open the valve.) In such cases, pilot pressure required to open the decompression poppet and valve can be calculated as follows:

To open valve or poppet in line A:

$$\text{Pressure at B}_1 = \frac{P_A + P_C - P_{A1}}{\text{Area ratio factor}} + P_{A1}$$

To open valve or poppet in line B:

$$\text{Pressure at A}_1 = \frac{P_B + P_C - P_{B1}}{\text{Area ratio factor}} + P_{B1}$$

Where:

P_A = Pressure at A

P_C = Cracking pressure

P_{A1} = Pressure at A1

P_B = Pressure at B

P_{B1} = Pressure at B1

In the above cases, substitute cracking pressure and area ratio from the following:

Cracking pressure: 1, 2.5 or 5 bar according to model code position 6 (and position 10 for second function).

Area ratio factors:

Standard valve: 3

Decompression poppet: 20

Model Code

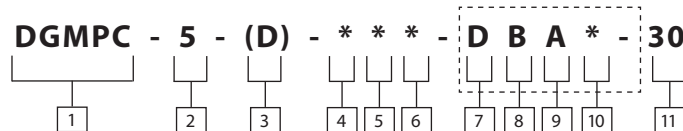

1 Valve function

Manifold or subplate mounted check valve.

2 Interface

5 – ISO 4401-AC-05-4-A, CETOP RP35H, Size 5 ANSI/NFPA D05

3 Decompression feature

D – With decompression feature
Blank – Standard (no decompression)

4 Check port

A – Check in cylinder port "A"
B – Check in cylinder port "B" (single check models only)

5 Pilot port

A – Pilot port controlling the "B" port check (single check models only)
B – Pilot port controlling the "A" port check

6 Cracking pressure

K – 1,0 bar (15 psi)
M – 2,5 bar (35 psi)
N – 5,0 bar (75 psi)

7 Decompression feature

D – Decompression feature
Blank – Standard (no decompression)
Omit for single check models.

8 Check port: second function

B – Check in cylinder port "B"
Omit for single check models.

9 Pilot port: second function

A – Pilot port controlling the "B" port check (dual check models only)
Omit for single check models.

10 Cracking pressure: second function

K – 1,0 bar (15 psi)
M – 2,5 bar (35 psi)
N – 5,0 bar (75 psi)
Omit for single check models.

11 Design number - 30 series

Subject to change. Installation dimensions unaltered for design numbers 30 to 39 inclusive.

DGMPC-5- AB*-30

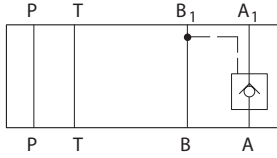

DGMPC-5- BA*-30

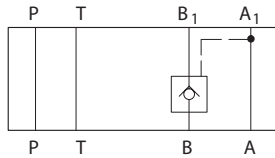

DGMPC-5- AB*-BA*-30

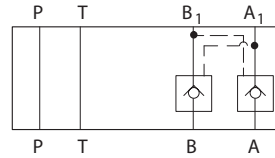

Operating Data

Basic Characteristics

| | |
|--|------------------------------|
| Maximum flow | 120 l/min (32 USgpm) |
| Maximum operating pressure | 315 bar (4500 psi) |
| Leakage @ 50°C (120°F) Poppet @ 35 bar (500 psi) | |
| Standard models | 0.3 ml/min. |
| "D" models | 1.0 ml/min. |
| Piston @315 bar (4500 psi) | 20°C to 50 °C (70 to 120° F) |
| Operating temperature | 20°C to 50°C (70° to 120°F) |
| Weights | 2,9 kg (6.4 lbs) |

Performance Data

DGMPC Pressure Drop

The curves below show pressure drop through each functional flow path in the valve. The total insertion loss for the valve must be calculated by summing the losses through the four applicable flow paths.

| ModelType | Curve Number | | | | | | | |
|----------------------------|--------------|---|---|---|---|---|---|---|
| | P | T | A | | B | | | |
| DGMPC-5-(D)-AB*-30 | 1 | 2 | - | 5 | ▲ | 3 | - | - |
| DGMPC-5-(D)-BA*-30 | 1 | 2 | 3 | - | - | - | 5 | ▲ |
| DGMPC-5-(D)-AB*-(D)-BA*-30 | 1 | 2 | 3 | 5 | ▲ | - | 5 | ▲ |

- Flow toward actuator without check – single check only
- Flow from actuator without check – single check only
- ▲ Use K, M, or N cracking pressure curve as applicable

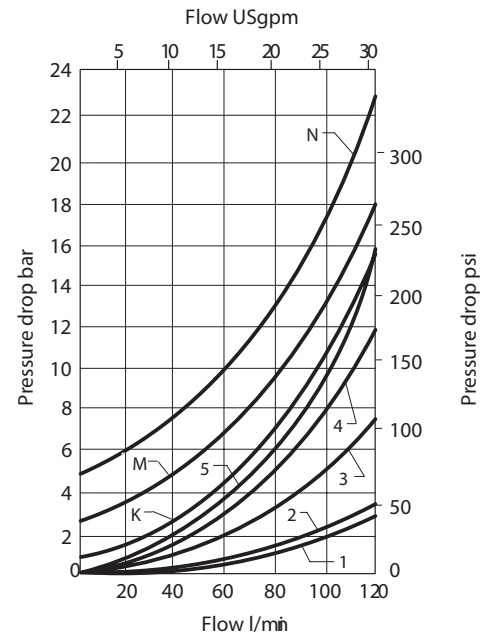

Installation Dimensions



DGMPC-5-30 Pilot Operated Check Valve mm (inches)

See page 38 for interface dimensions.

4 mounting holes
Ø 6,9 (0.27) through
Ø 9,50 (0.37) counterbore
36,5 (1.44) deep
for bolt extenders
(order separately)
BKE-6M-50M (M6 metric) or
BKE-4-50M (.2500-20 UNC)
Torque: 11,3-14,7 Nm
(100-130 lb. in.)

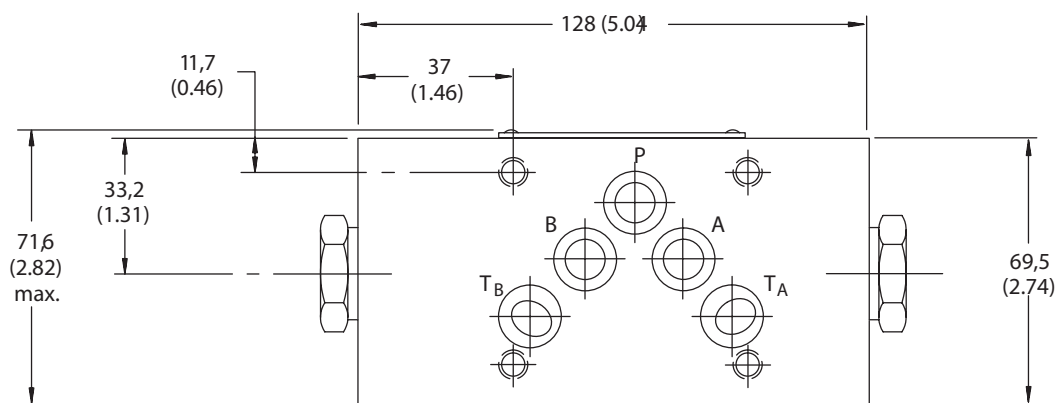
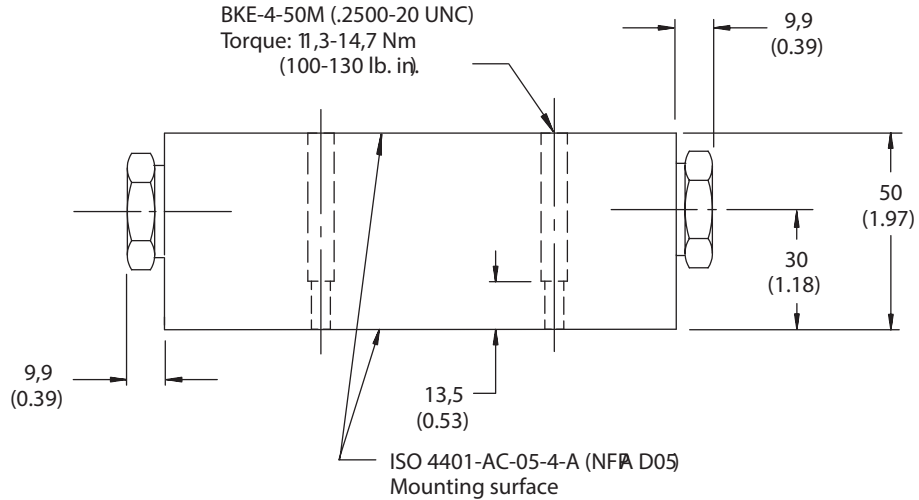

DGMDC

General Description

These SystemStak valves are self-operating, spring loaded, poppet type single or dual check units.

Location of the check element can be in the “A”, “B”, “P” or “T” port.

A check in the “P” port is available as a “Y” single check model only.

A check in the “T” port is available as an “X” single check model only.

The dual check unit has identical check elements in both the “A” and “B” ports.

Check valve cracking (opening) pressures of 1 bar (15 psi), 2,5 bar (35 psi) and 5 bar (75 psi) are available.

Model Code

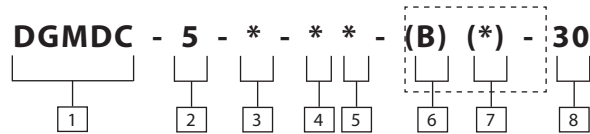

1 Valve function

Manifold or subplate mounted check valve.

2 Interface

5 – ISO 4401-AC-05-4-A, CETOP RP35H, Size 5 ANSI/NFPA D05

3 Direction of flow

X – Free flow from actuator (load)
Y – Free flow to actuator (load)

4 Check location

A – Check in cylinder port “A” (“Y” models only)
B – Check in cylinder port “B” (“Y” models only)
P – Check in pressure port “P” (“Y” models only)
T – Check in tank port “TA” (“X” models only)

5 Cracking pressure

K – 1,0 bar (15 psi)
M – 2,5 bar (35 psi)
N – 5,0 bar (75 psi)

6 Check location: second function

Omit for single check models.
B – Check in cylinder port “B” (dual check models only)

7 Cracking pressure: second function

Omit for single check models.
K – 1,0 bar (15 psi)
M – 2,5 bar (35 psi)
N – 5,0 bar (75 psi)

8 Design number - 30 series

Subject to change. Installation dimensions unaltered for design numbers 30 to 39 inclusive.

DGMDC-5- **Y-P***-30

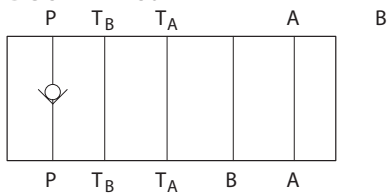

DGMDC-5- **Y-B***-30

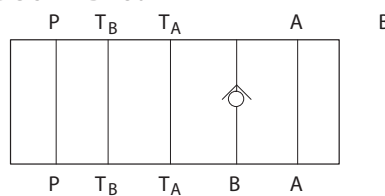

DGMDC-5- **X-T***-30

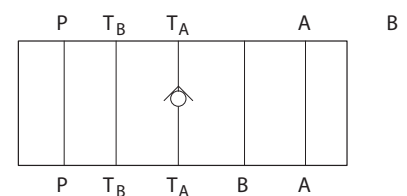

DGMDC-5- **Y-A***-**B***-30

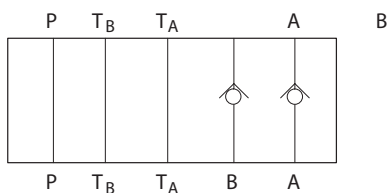

DGMDC-5- **Y-A***-30

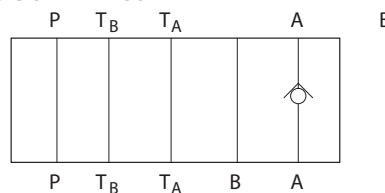

Basic Characteristics

| | |
|--|-----------------------------|
| Maximum flow | 120 l/min (32 USgpm) |
| Maximum operating pressure | 315 bar (4500 psi) |
| Leakage @ 50°C (120°F) Poppet @ 35 bar (500 psi) | 0.3 ml/min. |
| Operating temperature | 20°C to 50°C (70° to 120°F) |
| Weights | 2,9 kg (6.4 lbs) |

Performance Data

Pressure Drop

These curves show pressure drop through each possible flow path in the valve. The total insertion loss for the valve must be calculated by summing the losses through the four applicable flow paths.

| ModelType | Curve Reference for Flow Path | | | | Graph Number |
|--------------------|-------------------------------|---|----|----|--------------|
| | P | T | A | B | |
| DGMDC-5-Y-PK-30 | K | | | | 1 |
| DGMDC-5-Y-PM-30 | M | T | A | B | |
| DGMDC-5-Y-PN-30 | N | | | | |
| DGMDC-5-X-TK-30 | | K | | | 2 |
| DGMDC-5-X-TM-30 | P | M | A | B | |
| DGMDC-5-X-TN-30 | | N | | | |
| DGMDC-5-Y-AK-30 | | | K | •1 | 3 |
| DGMDC-5-Y-AM-30 | P | T | M | | |
| DGMDC-5-Y-AN-30 | | | N | ■2 | |
| DGMDC-5-Y-BK-30 | | | •1 | K | 3 |
| DGMDC-5-Y-BM-30 | P | T | | M | |
| DGMDC-5-Y-BN-30 | | | ■2 | N | |
| DGMDC-5-Y-A*-B*-30 | P | T | ▲ | ▲ | |

- Flow to actuator through cylinder port without check
- Flow from actuator through cylinder port without check
- ▲ Use K, M, or N curve from graph 3, as applicable

Graph 1

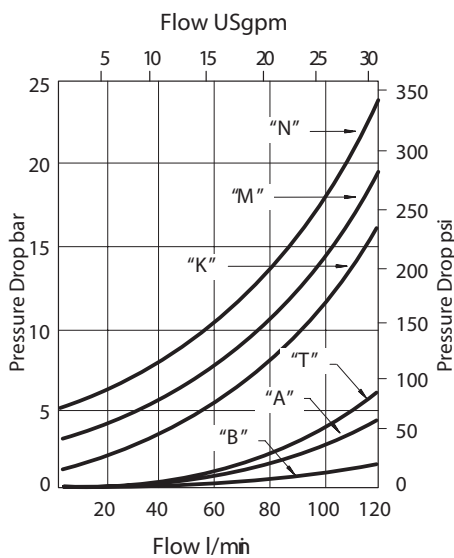

Graph 2

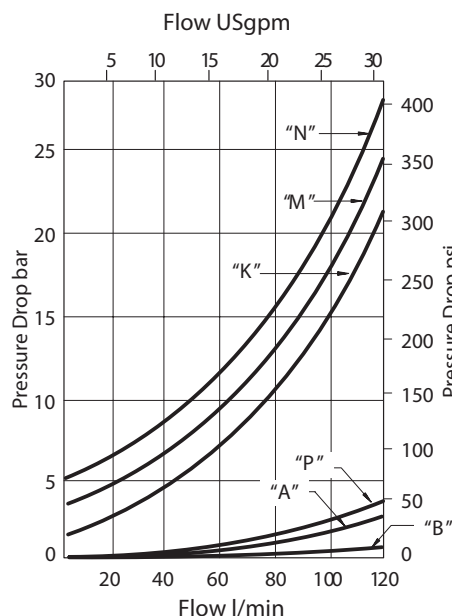

Graph 3

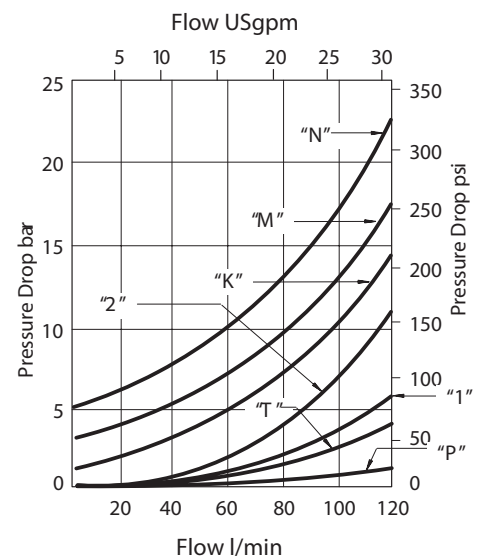

DGMDC-5-Y-A*-B*-30
Dual Direct Check Valve
 mm (inches)

4 mounting holes \varnothing 6,9 (0.27) through
 \varnothing 9,50 (0.37) counterbore 36,5 (1.44) deep
 for bolt extenders (order separately)
 BKE-6M-50M (M6 metric) or
 BKE-4-50M (.2500-20 UNC).
 Torque: 11,3-14,7 Nm (100-130 lb. in.)

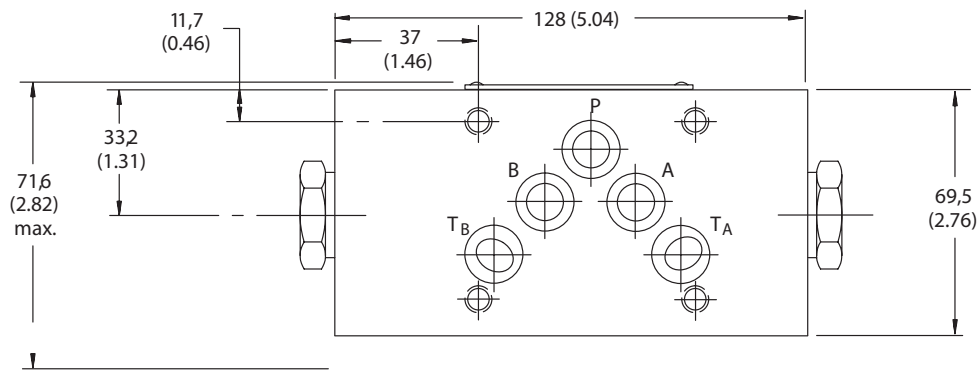
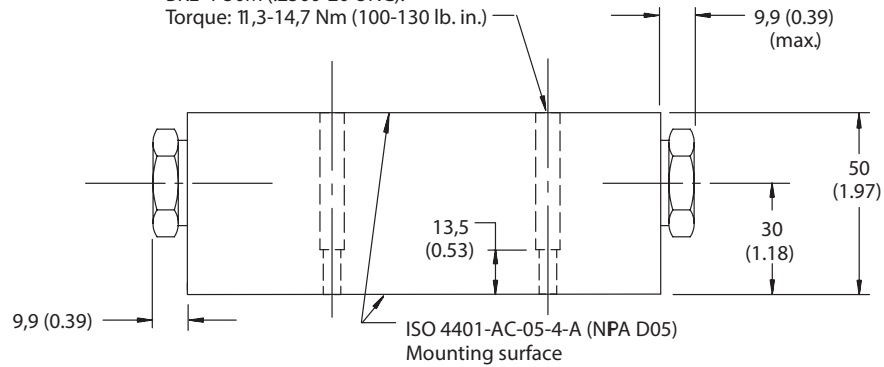

See page 38 for interface dimensions.

DGMDC-5-Y-P*-30
Single Direct Check Valve

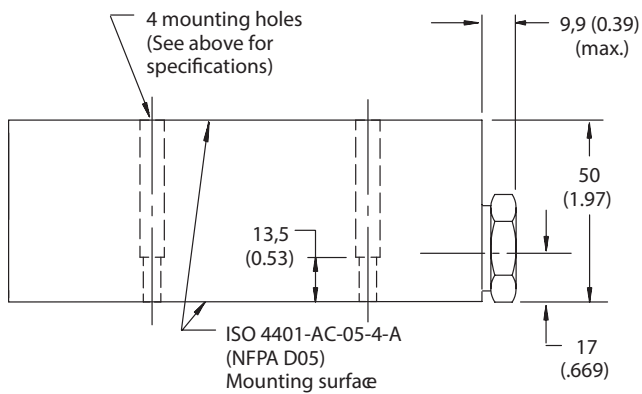

DGMDC-5-X-T*-30
Single Direct Check Valve

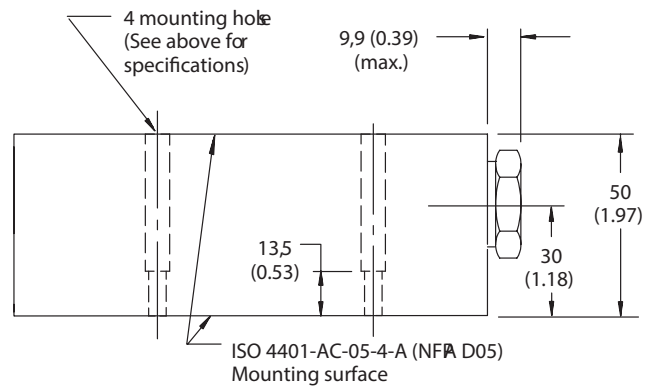

Knob Adjusters



DGMC
DGMC2 (dual type)
DGMR1
DGMX2

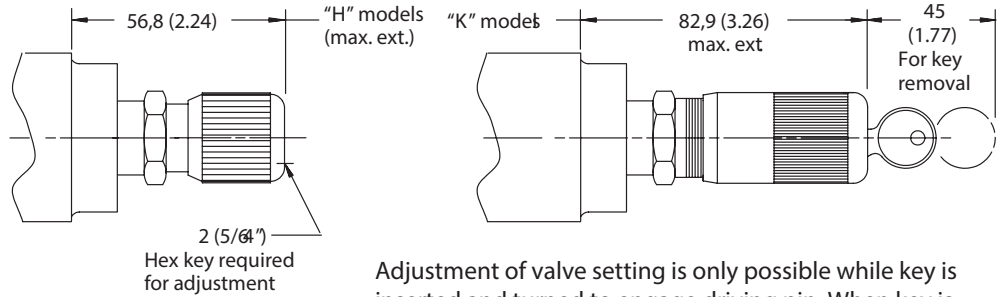

Adjustment of valve setting is only possible while key is inserted and turned to engage driving pin. When key is removed, adjuster knob can be freely spun and does not engage with setting mechanism.

DGMC2
(crossport type)

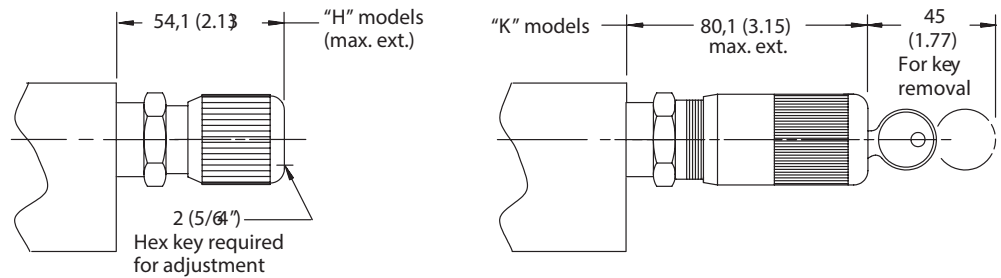

Adjustment of valve setting is only possible while key is inserted and turned to engage driving pin. When key is removed, adjuster knob can be freely spun and does not engage with setting mechanism.

DGMFN

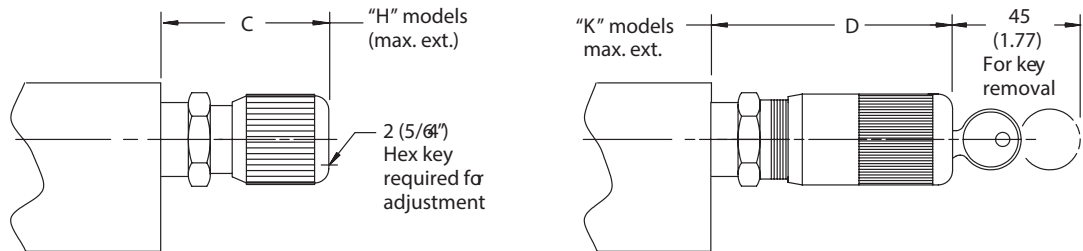

| Model | C | D |
|-------------|-------------|-----------|
| DGMFN-5-X-P | 68,9 (2.37) | 95 (3.74) |
| DGMFN-5-Y-A | 61,9 (2.44) | 88 (3.46) |

Adjustment of valve setting is only possible while key is inserted and turned to engage driving pin. When key is removed, adjuster knob can be freely spun and does not engage with setting mechanism.

DGMR

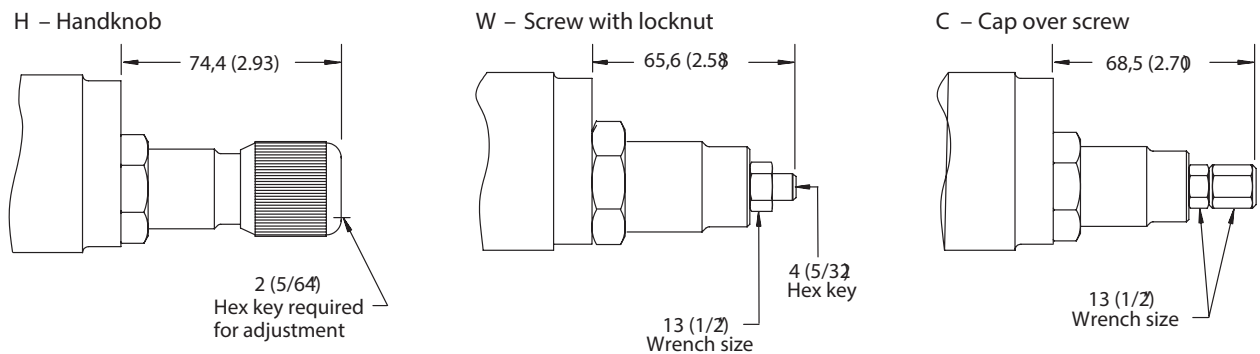

Mounting Surface



Dimensions mm (inches)

DGM**_5

The "5" interface accepts Eaton DG4S4 directional valves and other directional valves with a standard ISO 4401-05, NFPA-D05, ANSI/B93.7M size D05 or CETOP-5 port pattern.

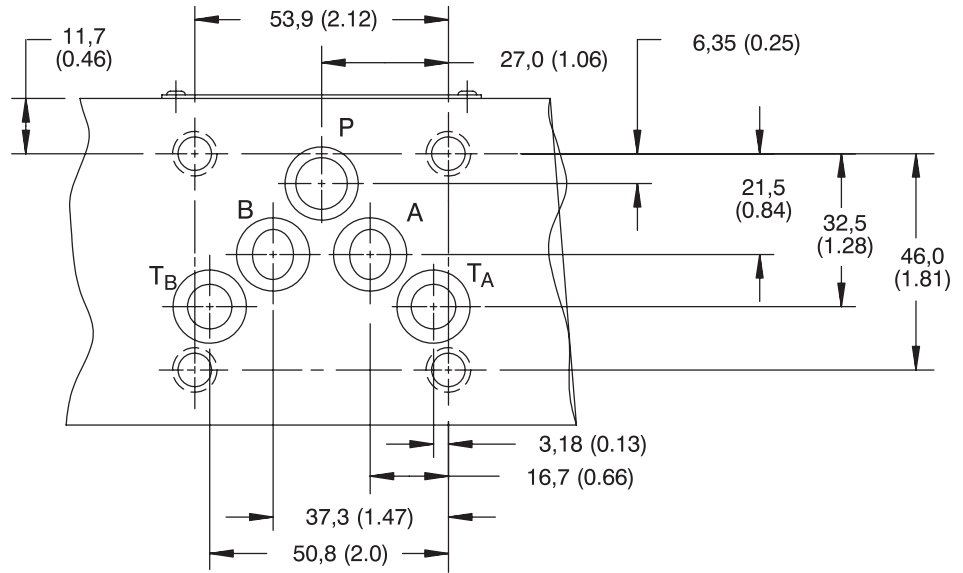

Bolt Extender Kits



ISO 4401-05 SystemStak valves may be mounted with either standard cap screws or bolt extender kits.

Metric cap screws must be of Class 12,9 (ISO 898) strength, minimum U.T.S. = 1200 MPa.

Inch threaded screws must conform to ANSI B18.3.

The use of Danfoss bolt extenders simplifies installation by permitting each valve body to be separately installed with the correct torque value. A major advantage of bolt extenders is the ability to remove the directional valve for service or replacement without disturbing the stack assembly. There are 4 bolt extenders per kit.

| SystemStak Valve Height | Metric | Kit Model Number | Inch | Kit Model Number | Extender Torque |
|-------------------------|-----------|------------------|--------------|------------------|-------------------------------|
| 50 (1.97) | M6 x 1-6H | BKE-6M-50M | .2500-20 UNC | BKE-4-50M | 11,3-14,7 Nm (100-130 lbf in) |
| 60 (2.36) | M6 x 1-6H | BKE-6M-60M | .2500-20 UNC | BKE-4-60M | |

Bolt extender cross section

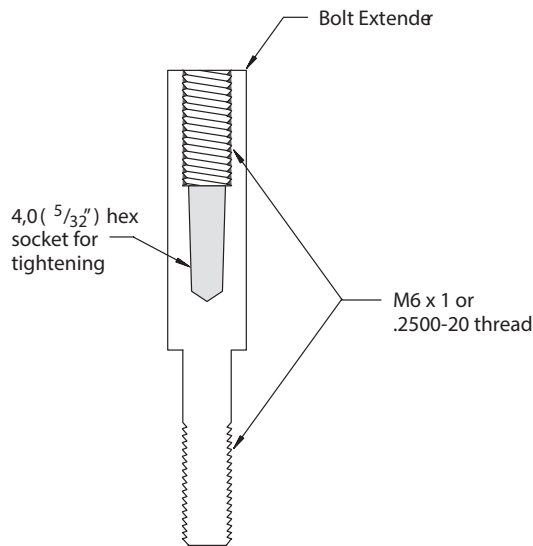

Example of bolt extenders on a typical SystemStak assembly

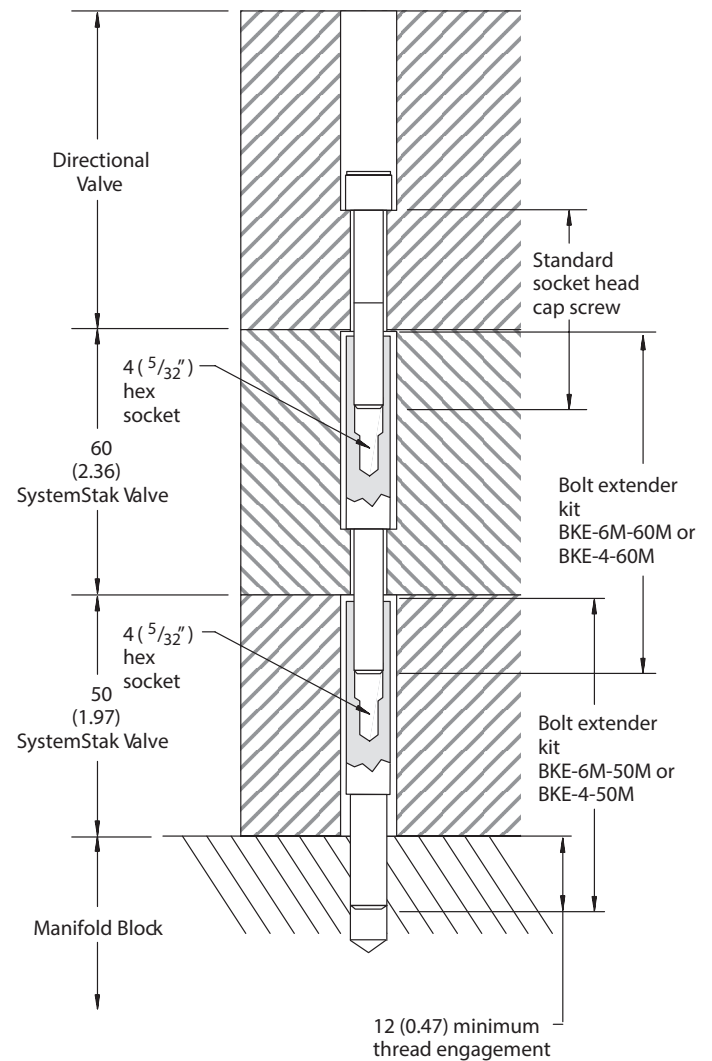

Subplates & Blanking Plate



Valves, subplates and blanking plates must be ordered separately.

DGSM(E) Subplate (rated at 210 bar (3000 psi))

Millimeters (inches)

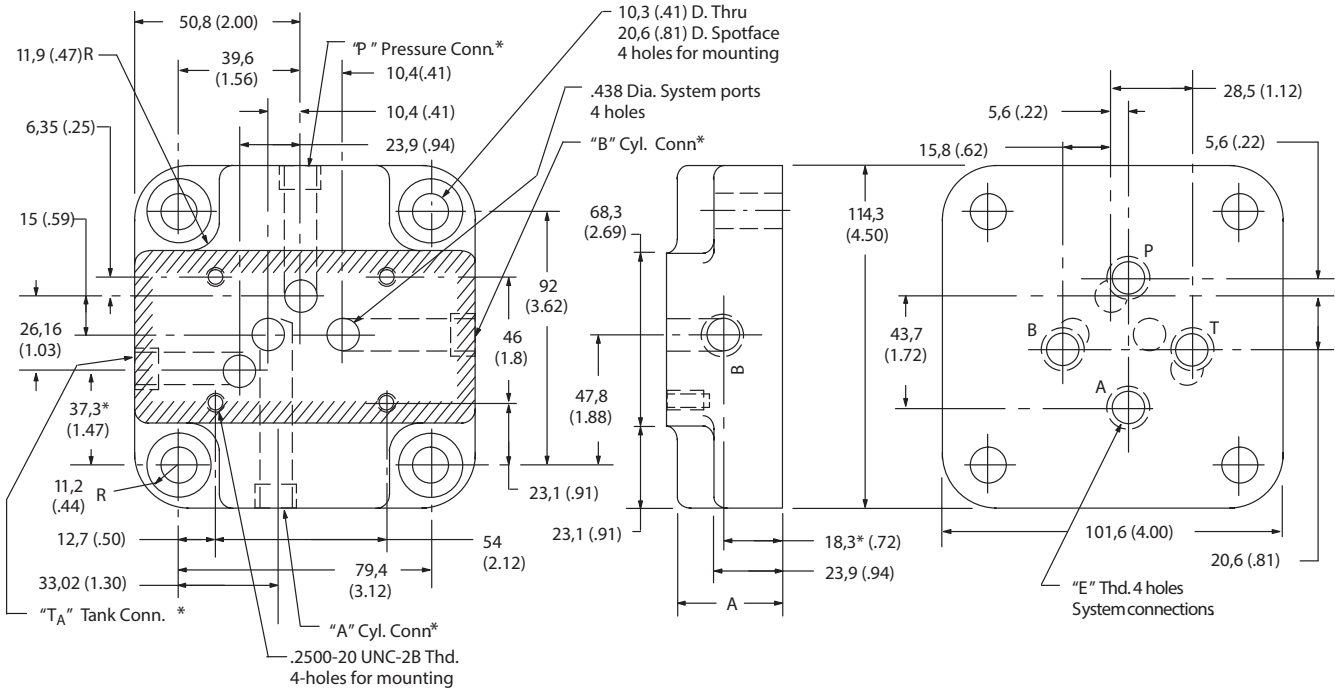

| Model Numbers | "E" Thread | Tube Size | Dimension "A" |
|----------------|----------------|-----------|---------------|
| DGSM-01-20-T8 | .750-16 UNF-2B | 1/2" O.D. | 31,75 (1.25) |
| DGSME-01-20-T8 | .750-16 UNF-2B | 1/2" O.D. | 38,10 (1.50) |

* Ports on side-connection Model DGSME-01-20-T8 only.

DGMAB-5-30 Blanking Plate

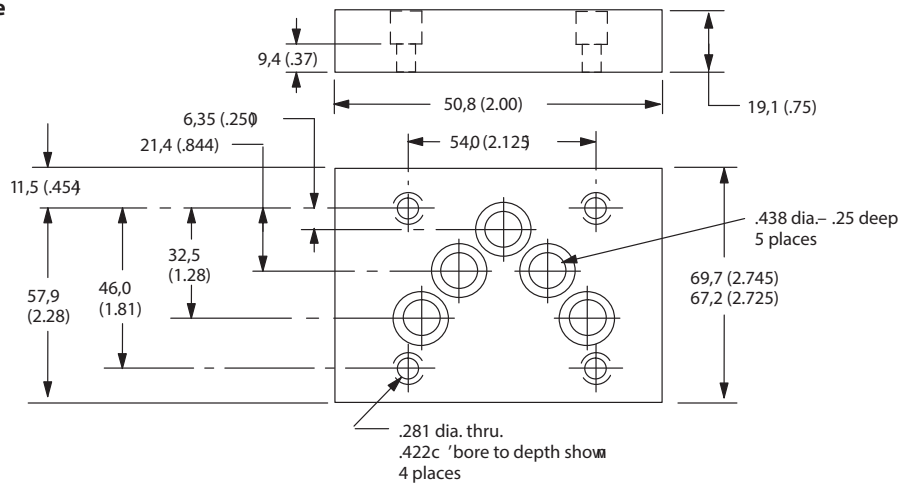

Subplates & Blanking Plates



DGVME Side Ported Subplates (rated at 315 bar (4500 psi) "5" interface

| Model | "X" | Assembly |
|-----------------------|--------|----------|
| DGVME-5-SP-10-T06 | .5625 | 525815 |
| DGVME-5-SP-10-T08 | .7500 | 525816 |
| DGVME-5-SP-10-T10 | .8750 | 525817 |
| DGVME-5-SP-10-T12 | 1.0625 | 525818 |
| DGVME-5-SP-PD-10-T10† | .8750 | 526003 |
| DGVME-5-SP-PD-10-T12† | 1.0625 | 526004 |

† Model with pilot and drain ports.

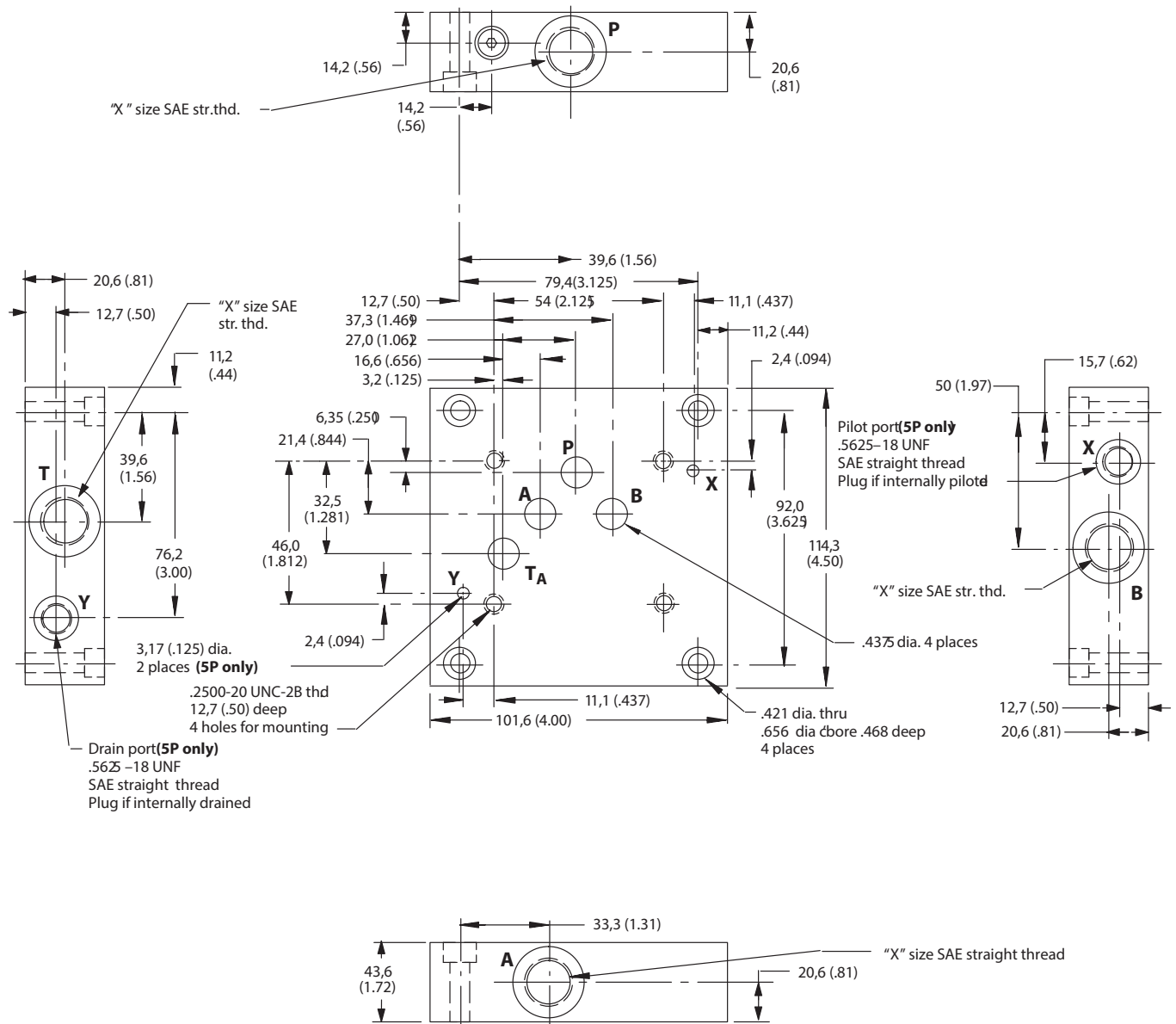

Subplates & Blanking Plates



DGVM Bottom Ported Subplates (rated at 315 bar (4500 psi) "5" interface

| Model | "X" | Assembly |
|----------------------|--------|----------|
| DGVM-5-SP-10-T06 | .5625 | 525811 |
| DGVM-5-SP-10-T08 | .7500 | 525812 |
| DGVM-5-SP-10-T10 | .8750 | 525813 |
| DGVM-5-SP-10-T12 | 1.0625 | 525814 |
| DGVM-5-SP-PD-10-T10† | .8750 | 525832 |
| DGVM-5-SP-PD-10-T12† | 1.0625 | 525833 |

† Model with pilot and drain ports.

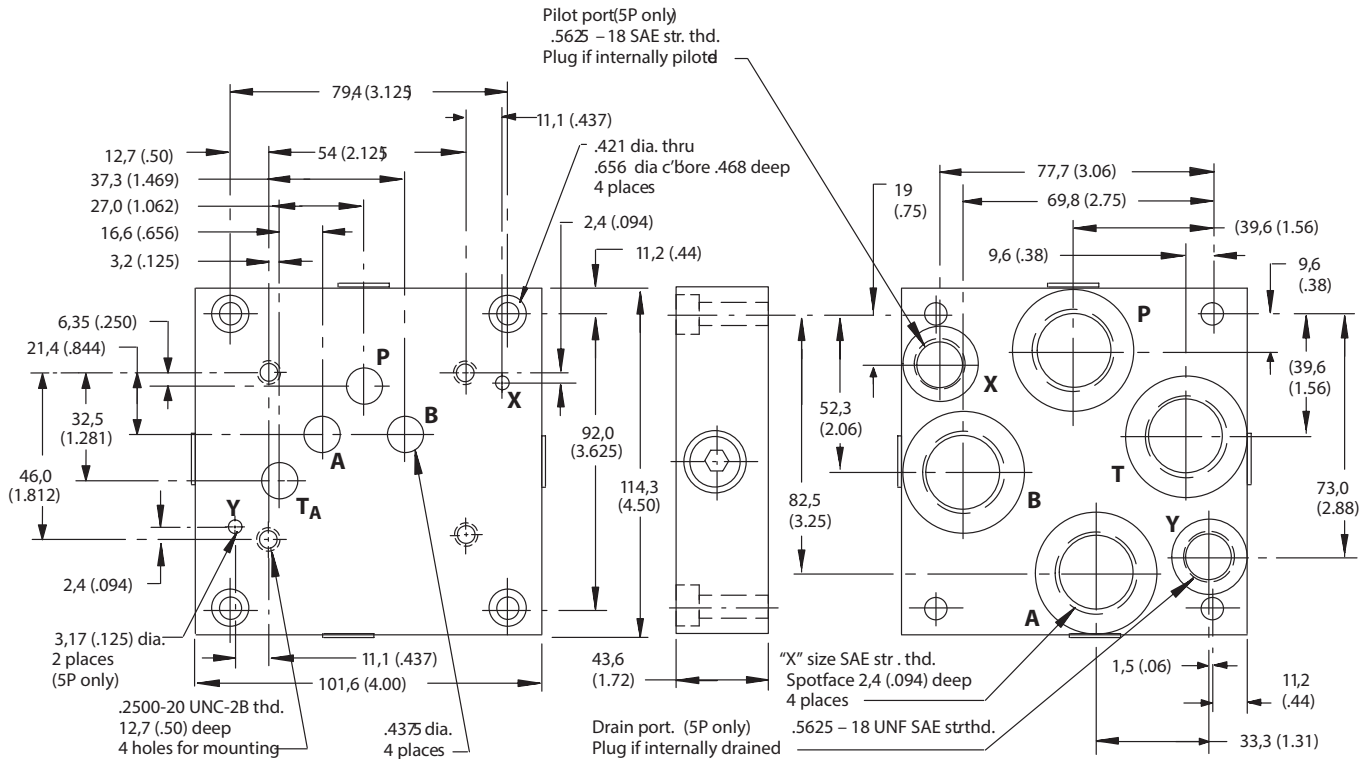

Products we offer:

- Cartridge valves
- DCV directional control valves
- Electric converters
- Electric machines
- Electric motors
- Gear motors
- Gear pumps
- Hydraulic integrated circuits (HICs)
- Hydrostatic motors
- Hydrostatic pumps
- Orbital motors
- PLUS+1® controllers
- PLUS+1® displays
- PLUS+1® joysticks and pedals
- PLUS+1® operator interfaces
- PLUS+1® sensors
- PLUS+1® software
- PLUS+1® software services, support and training
- Position controls and sensors
- PVG proportional valves
- Steering components and systems
- Telematics

Danfoss Power Solutions is a global manufacturer and supplier of high-quality hydraulic and electric components. We specialize in providing state-of-the-art technology and solutions that excel in the harsh operating conditions of the mobile off-highway market as well as the marine sector. Building on our extensive applications expertise, we work closely with you to ensure exceptional performance for a broad range of applications. We help you and other customers around the world speed up system development, reduce costs and bring vehicles and vessels to market faster.

Danfoss Power Solutions – your strongest partner in mobile hydraulics and mobile electrification.

Go to www.danfoss.com for further product information.

We offer you expert worldwide support for ensuring the best possible solutions for outstanding performance. And with an extensive network of Global Service Partners, we also provide you with comprehensive global service for all of our components.

Local address:

Hydro-Gear

www.hydro-gear.com

Daikin-Sauer-Danfoss

www.daikin-sauer-danfoss.com

**Danfoss
Power Solutions (US) Company**
2800 East 13th Street
Ames, IA 50010, USA
Phone: +1 515 239 6000

**Danfoss
Power Solutions GmbH & Co. OHG**
Krokamp 35
D-24539 Neumünster, Germany
Phone: +49 4321 871 0

**Danfoss
Power Solutions ApS**
Nordborgvej 81
DK-6430 Nordborg, Denmark
Phone: +45 7488 2222

**Danfoss
Power Solutions Trading
(Shanghai) Co., Ltd.**
Building #22, No. 1000 Jin Hai Rd
Jin Qiao, Pudong New District
Shanghai, China 201206
Phone: +86 21 2080 6201