

* incl. 20 [-5; +30] mm pull out

3D model is available on request or www.hyva.com

Specifications		Max. pump flow		Tipping time	
Max. working pressure	190 bar	With KO ¹	190 L/min	With KO ¹	31 sec
Weight	274 kg	Without KO ¹	137 L/min	Without KO ¹	43 sec
Working volume	98 L	With KO ¹ below -20°C	133 L/min	With KO ¹ below -20°C	44 sec
Total volume	106 L	Without KO ¹ below -20°C	96 L/min	Without KO ¹ below -20°C	61 sec
Max. cyl. load (start tipping)	245 kN			Allowable lowering time	31 sec
Max. cyl. load (end of stroke) ²	99 kN				
Max. cyl. load (end of stroke) ³	115 kN				

Technical notes

- This cylinder is a lifting device only. • It should not be used as a structural member and should not be subjected to side loads. • Tipping valve must have a pressure relief at the cylinder port set not higher than max. working pressure. • Verify max. cyl. load. • Working temperature range is between -40°C and +80°C. • Max. duration of extension is 0.5 hours (excluded hard chromed stages). • Cylinder is painted grey (DB7350) with a min. thickness conforming to the 480 hours neutral salt spray test as per ISO 9227. • ¹ Hyva knock-off. • ² Unsubstantial unloading (sticky load). • ³ Substantial unloading. • 50 mm clearance required between the headboard and the stages at end of stroke (deviation from CYL-0031).

Related documentation

Bracket options:	015BRA10 & 015BRA13
Mounting instructions:	CYL-0031
Oil specifications:	OIL-0011
Spec sheet explanation:	CYL-0041

Configuration

Extension	1	2	3	4	5	6	7	Total
Effective diameter [mm]	169	149	129	110	91			6730
Stroke* [mm]	1470	1490	1490	1490	790			

Tipping weight

For detailed tipping calculations please refer to: <https://tipper.hyva.com>

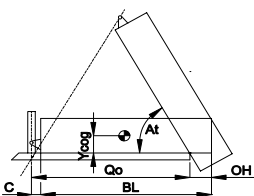

BL body length
OH rear overhang
Ycog vert. pos. centre of gravity
Qo pivot length
C bracket length
At tipping angle
stroke x 60 / Qo

BL [mm]	8900			8500			8100		
OH [mm]	200	500	800	200	500	800	200	500	800
At [°]	45	47	49	48	50	52	50	53	55
Ycog [mm]									
600	33	36	38	34	37	40	36	39	43
900	35	38	41	37	40	44	39	42	48
1200	38	41	45	39	43	49	42	47	54

Tipping weight [ton] at maximum pressure of 190 bar for a vertically mounted cylinder and C is 158 mm

Pos.	Part no.	Description	Qty.
C01	71838901	DUST COVER FES 169-5	1
P01	74462703	PISTON FL3 S 091-1732-HC (SR=700)	1
P02	71853091K	SLIDER FL 091 (2 X 1/2) A22	1
P03	71851091K	OUTER STOPRING FL 091 A22	1
P04	71822091	BOTTOM PLATE PISTON FL 091	1
P05	01745012K	CIRCLIP 82 DIN 472 (87.5x2.5)	1
P06	71870215K	O-RING PISTON BOTTOM 091	1
P07	71847201	PISTON EYE SPH. FL3 091 L=075 GR	1
P08	01226430K	O-RING 72.62 X 3.53 MM	1
P09	01770085K	SPHERICAL BEARING D.50.3 DO GREASED	1
P10	01770560K	CIRCLIP 75 DIN 472 (79.5x2.5)	1
P11	71875012	PIN ROUND HEAD GROOVED 8x15 mm	2
P12	56288044K	GREASE NIPPLE M8x1 DIN 71412	1
P13	01317670K	GREASER PROTECTION CAP	1

S41	74603700	STAGE FL2 110-1700	1
S42	71802110K	PACKSET FL 110	1
S43	71853110K	SLIDER FL 110 (2 X 1/2) A22	1
S44	71851110K	OUTER STOPRING FL 110 A22	1
S45	71852110K	LIFTRING FL 110 A22	1

S31	74604700	STAGE FL2 129-1700	1
S32	71802129K	PACKSET FL 129/HP 129	1
S33	71853129K	SLIDER FL 129 (2 X 1/2) A22	1
S34	71851129K	OUTER STOPRING FL 129 A22	1
S35	71852129K	LIFTRING FL 129 A22	1

S21	74605700	STAGE FL2 149-1700	1
S22	71802149K	PACKSET FL 149/HP 150	1
S23	71807151K	SLIDER FL 149 A35	1
S24	71851149K	OUTER STOPRING FL 149 A22	1
S25	71852149K	LIFTRING FL 149 A22	1

S11	74606700	STAGE FL2 169-1700	1
S12	71802169K	PACKSET FL 169	1
S13	71807171K	SLIDER FL 169 A35	1
S14	71851169K	OUTER STOPRING FL 169 A22	1
S15	71813169K	LIFTRING FL 169x5	1

B01	74507691	BASE FL2 191-1743-4/4BSAE-190-TP290	1
B02	71802191K	PACKSET FL 191	1
B03	71825430	BOTTOM PLATE FL2 191	1
B04	71870040K	SEAL BOTTOM PLATE FL 191	1
B05	71820195	LOCKING PLATE FL2 191	3
B06	01732055K	BOLT HEX M8X20X1.25 SET 6 PCS	1
B07	01732559K	WASHER SPRING M8 SET 6 PCS	1

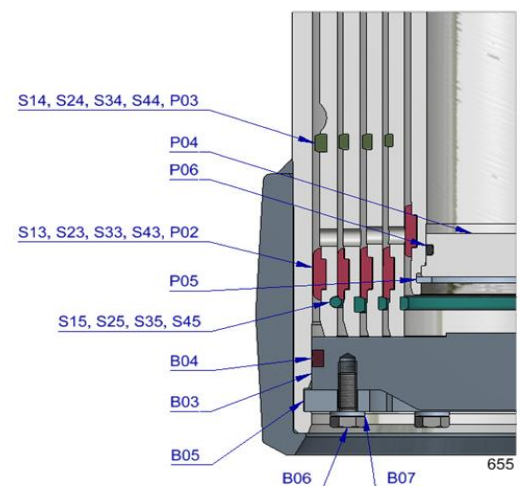
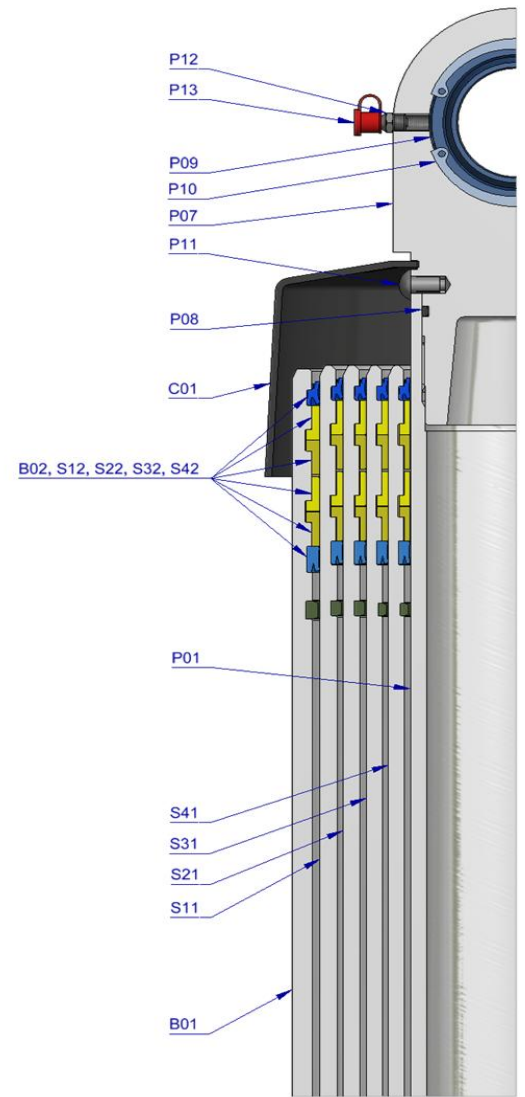

Seal kit complete

71908650K	Consists of all packsets with packset grease and O-rings
-----------	----------------------------------------------------------

Notes

The inner stopring and piston bottom are pre-mounted on spare bases, stage and pistons. Therefore, when ordering new tubes, it is not required to order these parts separately.

For repair instructions see: CYL-0040. Serial no. is located on type plate and near type plate support.